

N2 W3 A 0,9<sub>m</sub>

AS-BLB.K



**asebal**

Vehicle Restraint System

### Definition

Single metal barrier reduced for lateral side. System formed by a double wave barrier and C posts 4 metres apart.

### Performance parameters

Containment level	<b>N2</b>	Working Width (W)	<b>W3</b>	Impact Severity	<b>A</b>	Dynamic Deflection (D)	<b>0,9<sub>m</sub></b>
-------------------	-----------	-------------------	-----------	-----------------	----------	------------------------	------------------------

### Profile

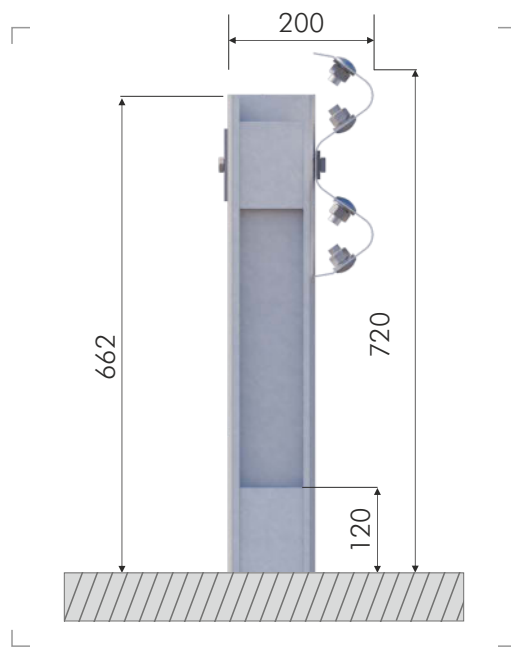

N2 W3 A 0,9<sub>m</sub>

AS-BLB.K



asebal

Vehicle Restraint System

### Components for sections of 4 m

Ítem	Parts	Uds
1	Standard barrier of 4 m (Central perforated and at intervals of 1,33 m, 2 mm thick)	1
2	C post 120 of 1,500 mm lateral perforation	1
3	Reinforcement C-108,5x44x28 of 250 mm	1
4	Reinforcement C-108,5x44x28 of 120 mm	1
5	Round head bolt M16x30	8
6	Hexagon head cup bolt DIN 933 M12x50 quality 10.9	1
7	Hexagon head cup bolt DIN 933 M12x40 quality 10.9	1
8	Hexagon nut M16	8
9	Nut DIN 934 M12 Class 10	2
10	Washer Ø17 x35x4 mm	8
11	Washer 100x40x5 mm M12	2
12	Washer DIN 125 M12	1
13	Washer 100x25x5 mm M12	2
14	Reflector	0,5

### Fasteners

