

N2 W5 A 1,6m

AS-BLB.D

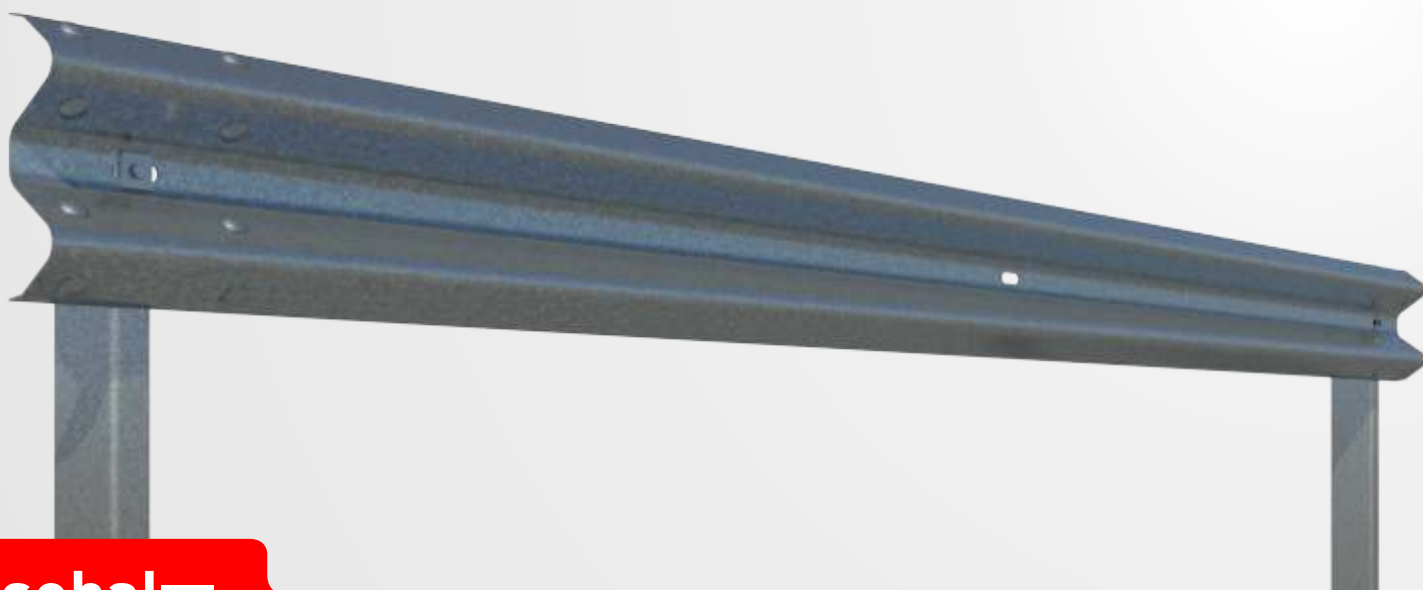

CE



asebal

Vehicle Restraint System

Definition

Single metal barrier reduced for lateral side. System formed by a double wave barrier and C posts 4 metres apart.

Performance parameters

Containment level	N2	Working Width (W)	W5	Impact Severity	A	Dynamic Deflection (D)	1,6m
-------------------	-----------	-------------------	-----------	-----------------	----------	------------------------	-------------

Profile

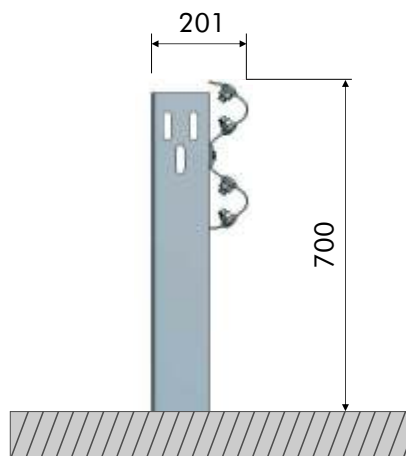

N2

W5

A

1,6m

AS-BLB.D

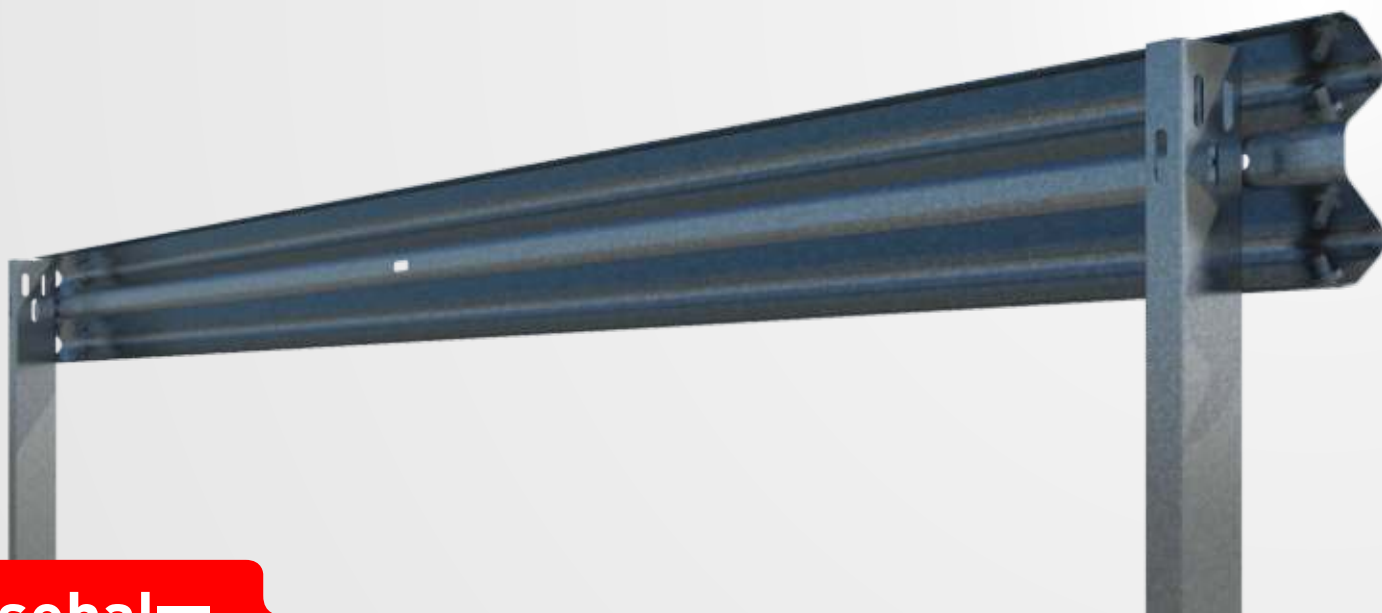

CE

asebal
Vehicle Restraint System

Components for sections of 4 m

Item	Part	Uds
1	Standard barrier of 4 m	1
2	C post-120 of 1500 mm	1
3	Reflector	0,5
4	Round head bolt M16x30, with nut	8
5	Hexagon head cap bolt M10x40	1
6	M10 nut	2
7	Washer $\varnothing 17 \times 35 \times 4$ mm	8
8	Square washer 40x40x5 mm	2

Fasteners

