

H1 W4 A 1,0_m

AS-BMSNC2/C

CE

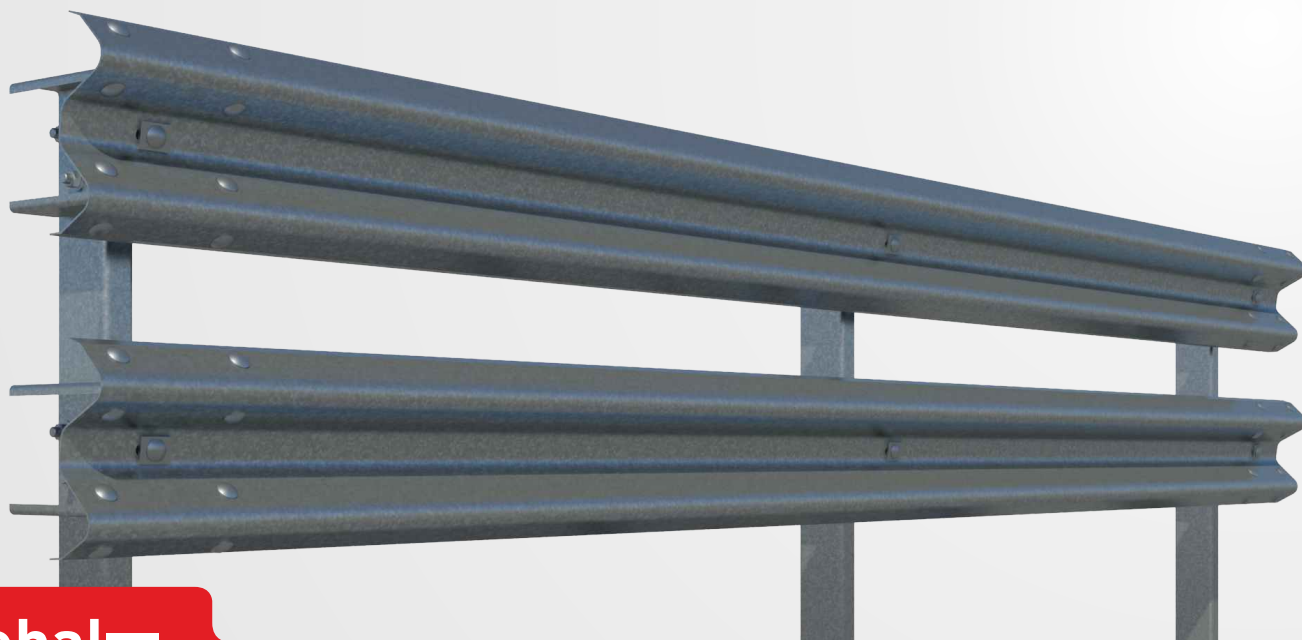

asebal

Vehicle Restraint System

Definition

Superimposed single metal barrier for lateral side. System formed by two double wave barriers, spacer and C posts 2 metres apart.

Performance parameters

Containment level	H1	Working width (W)	W4	Impact Severity	A	Dynamic Deflection (D)	1,0 _m
-------------------	----	-------------------	----	-----------------	---	------------------------	------------------

Profile

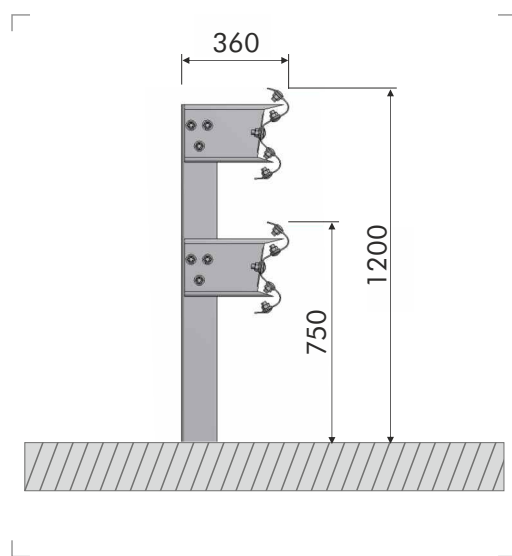



asebal

Vehicle Restraint System

Components for sections of 4 m

Item	Part	Uds
1	Standard barrier of 4 m	2
2	C post-120 of 2,000 mm DP	2
3	Standard spacer	4
4	Bolt M16x40, with nut	4
5	Bolt M16x35, with nut	12
6	Bolt M16x30, with nut	16
7	Rectangular washer 55x40x5 mm	4
8	Washer Ø17 x35x4 mm	32
9	Reflector	1

Fasteners

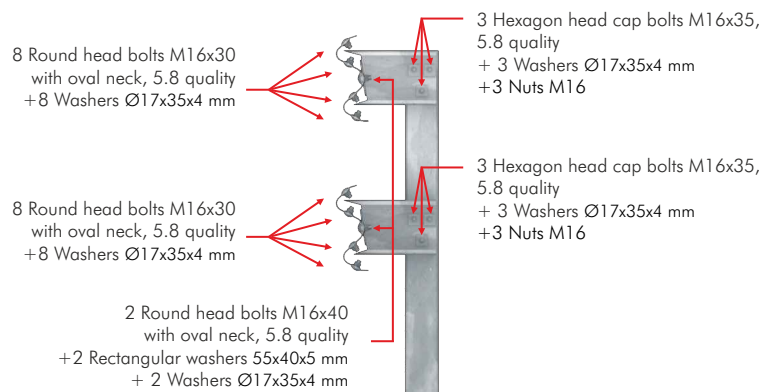

Detail of joint between barriers

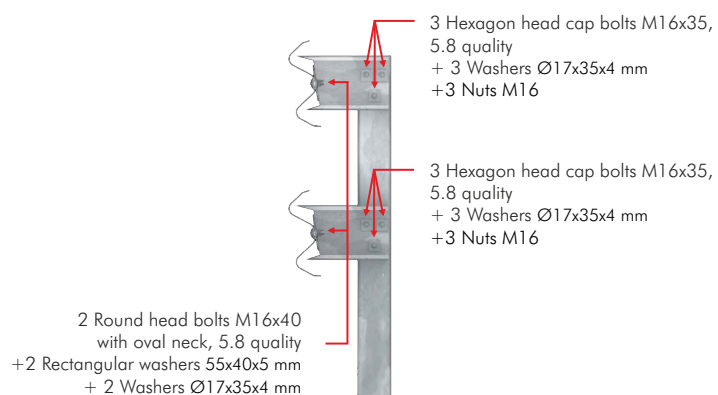

Detail of joint in intermediate post