

H1 W4 A 1,2<sub>m</sub> VI6

AS-ME1.B



CE



**asebal**

Vehicle Restraint System

### Definition

Symmetrical metal barrier for median strip. System formed by two double wave barriers, and C posts four metres apart.

### Performance parameters

Containment level	<b>H1</b>	Working width (W)	<b>W4</b>	Impact Severity	<b>A</b>	Dynamic Deflection (D)	<b>1,2<sub>m</sub></b>
Intrusion (I)	<b>VI6</b>						

### Profile

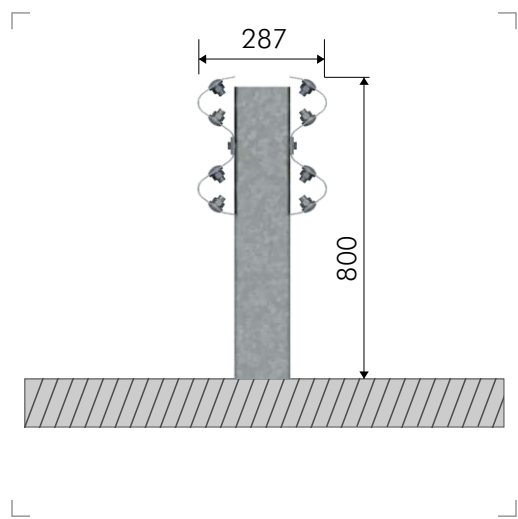

H1 W4 A 1,2m VI6

AS-ME1.B

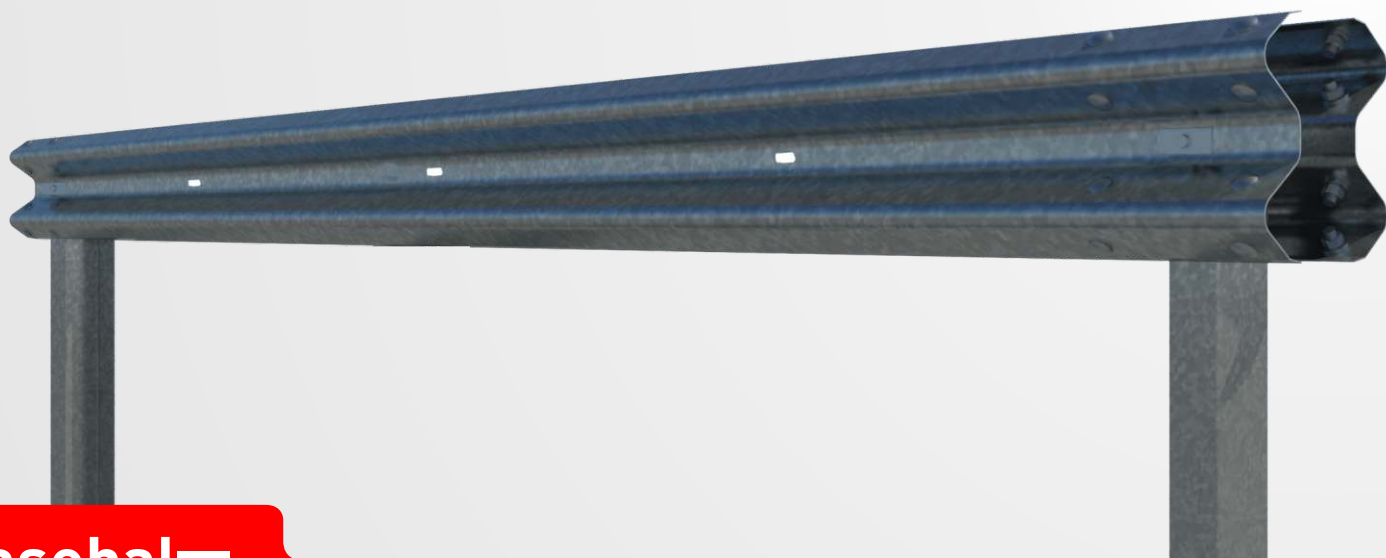

**asebal**

Vehicle Restraint System

### Components for sections of 4 m

Item	Part	Uds
1	Straight barrier of 4 m	2
2	C post of 125x75x20 of 1,600 mm	1
3	Round head bolt M16x30	16
4	Bolt DIN 933 M10x40	2
5	Washer Ø17x35x4mm	16
6	Rectangular washer 100x40x5 mm Ø11 for M10	2
7	Square washer 40x40x5 mm Ø11 for M10	2
8	Nut M16	16
9	Nut M10	2
10	Reflector	1

### Fasteners

