

N2 W5 A 1,4m

AS-BLB.I

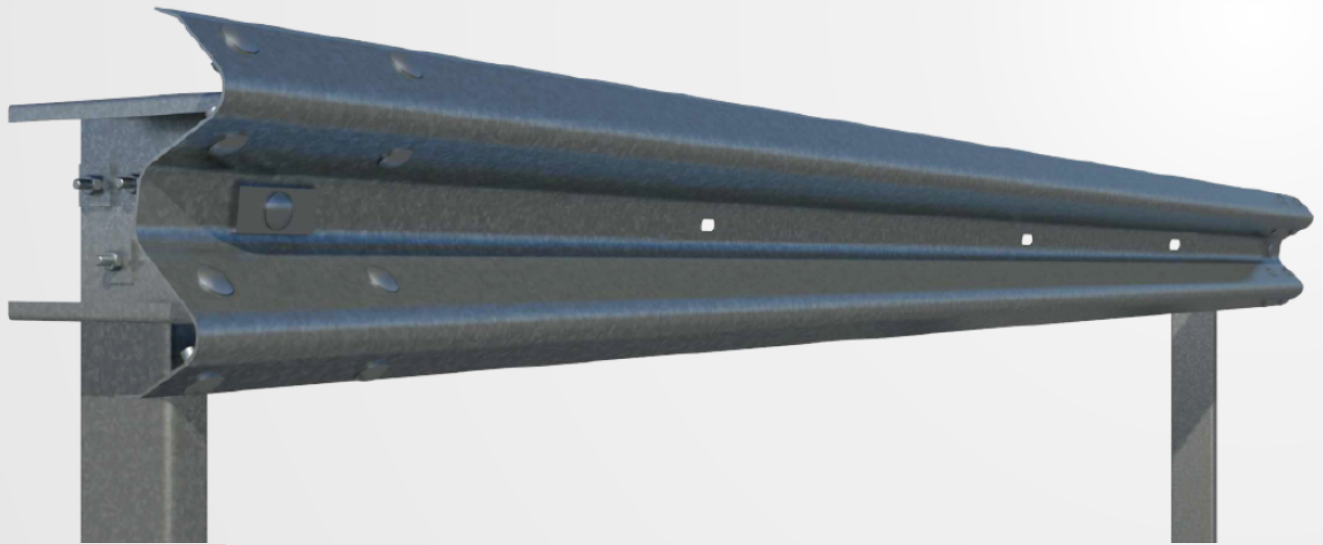

CE



asebal

Vehicle Restraint System

Definition

Single metal barrier for lateral side. System formed by a double wave barrier, spacer and C posts 4 metres apart.

Performance parameters

Containment level	N2	Working Width (W)	W5	Impact Severity	A	Dynamic Deflection (D)	1,4m
-------------------	-----------	-------------------	-----------	-----------------	----------	------------------------	-------------

Profile

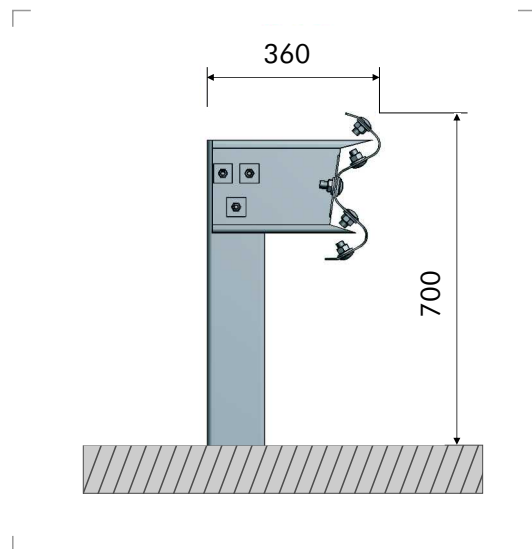

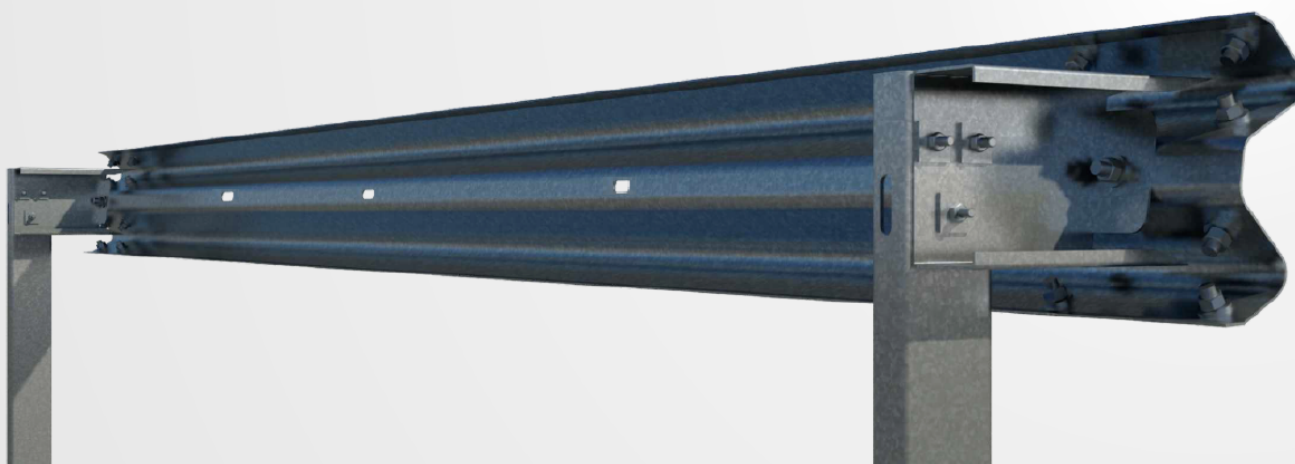

Components for sections of 4 m

Item	Part	Uds
1	Standard barrier of 4 m (Perforated at intervals of 1,33 m, 2 mm thick)	1
2	C post-120 of 1,500 mm	1
3	Standard spacer	1
4	Reflector	0,5
5	Round head bolt M16x30, with nut	8
6	Round head bolt M16x40, with nut	1
7	Hexagon head cap bolt M10x40	3
8	M10 nut	3
9	Washer Ø17x 35x4 mm	9
10	Rectangular washer 100x40x5 mm	1
11	Square washer 40x40x5 mm	6

Fasteners

