

H1	W5	A	1,4m	Severity I UNE 135900
----	----	---	------	-----------------------------

AS-SM6.B (R4-H1) 

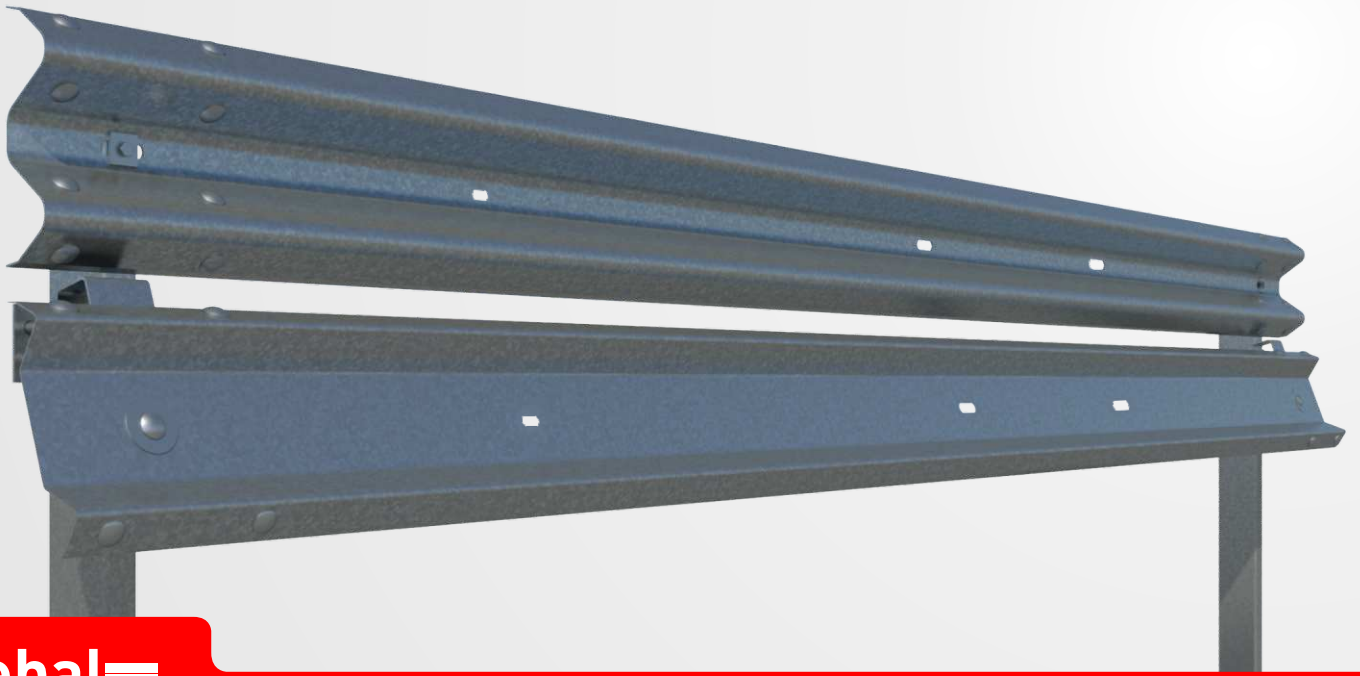



asebal 

Vehicle Restraint System

Definition

Single metal barrier reduced for lateral side with motorcyclist protection system. System formed by a double wave barrier, protective beam for motorcyclists and C posts 4 metres apart.

Performance parameters

Containment level	H1	Working width (W)	W5	Impact Severity	A	Dynamic Deflection (D)	1,4m
Impact Severity level	I						

Profile

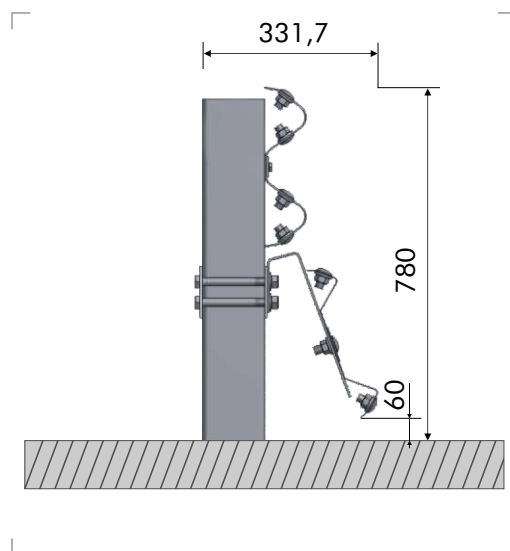



AS-SM6.B (R4-H1)

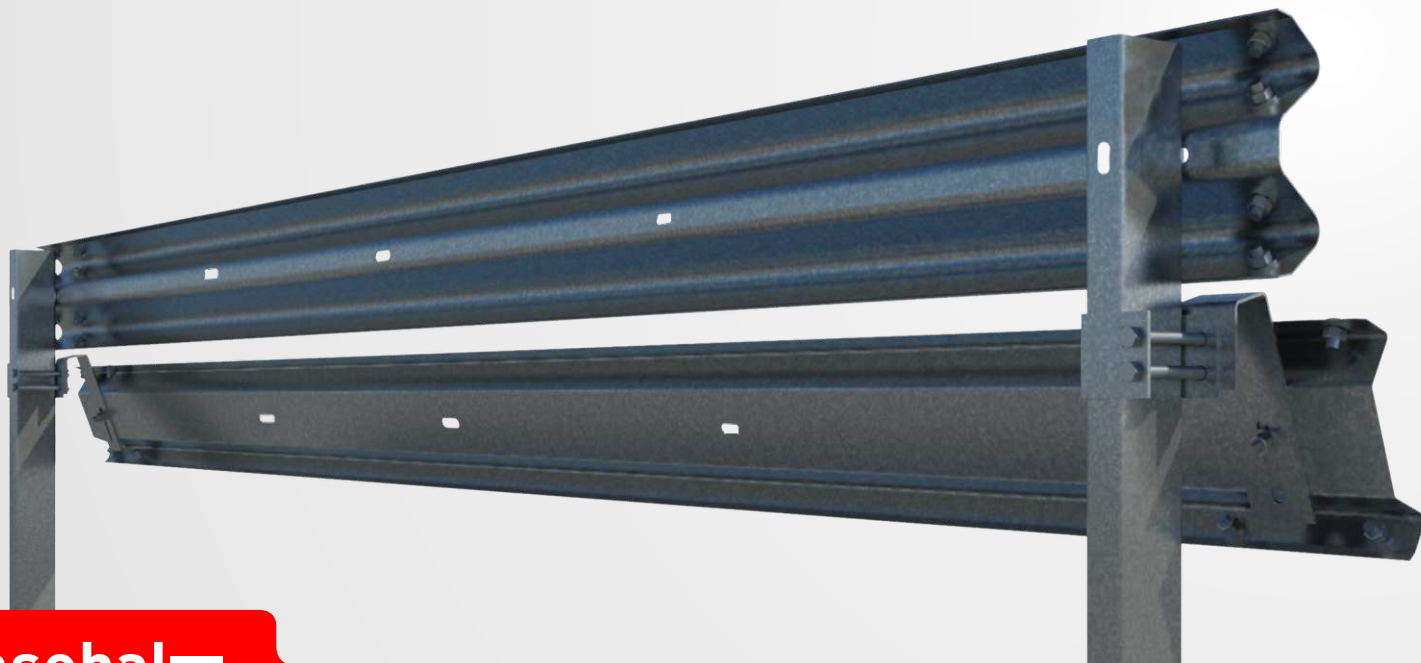

asebal

Vehicle Restraint System

Components for sections of 4 m

Item	Part	Uds
1	Standard barrier of 4 m (central and at intervals of 1.33 m perforated)	1
2	C-125 post of 1,600 mm	1
3	Protective beam for motorists, of 4 m (central and at intervals of 1.33 m perforated)	1
4	Anchorage for reduced AS.SM6.B	1
5	U support for C-125x75 post	1
6	Round head bolt M16x30 mm	12
7	Round head bolt M16x40 mm	1
8	Hexagon head cap bolt DIN 931 M16x160 mm	2
9	Hexagon head cap bolt DIN 931 M10x40 mm	1
10	Washer Ø17x35x4 mm	15
11	Square washer 40x40x5 mm for M10	1
12	Washer Ø70 mounting hole 30x18	1
13	Washer 100x40x5 mm for M10	1
14	DIN 934 M1 nut	1
15	M16 nut	15
16	Reflector	0,5

Fasteners

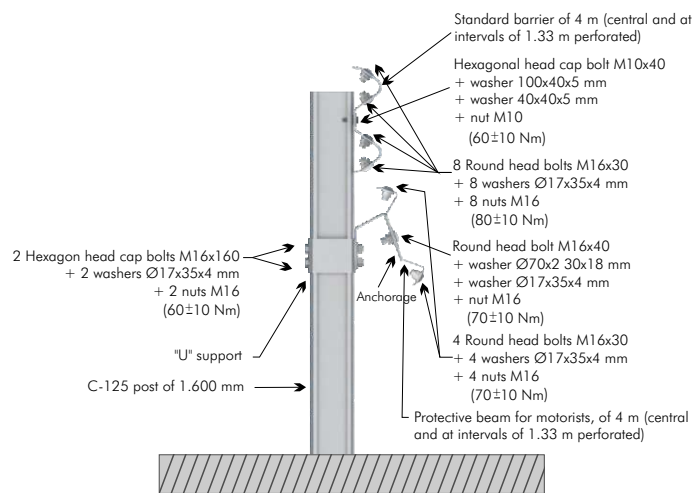

Detail of joint between barriers