



This product is:



asebal

Redirective end terminal

Definition

ATT Terminal is an end terminal with two important features: guarantees the highest levels of security at a competitive price.

The accurate design of ATT Terminal by Snoline, has led to the development of a new security system for end terminal.

With the new and calibrated teeth-cutting system, ATT Terminal, in a frontal or lateral impact ensures high energy absorption capacity, decelerating and redirecting the vehicle within the roadway, safeguarding the security of passengers.

The ATT Terminal is easy to install, does not require foundation works and, thanks to the use of standard guardrails components, allows to minimize inventory and maintenance costs.

Advantages

- Conforms to ENV1317-4 criteria Class P4 - speed 110 km/h
- Easy to transport and install
- No foundations are needed
- A team of 3 people can install ATT Terminal in 1 hour
- ATT Terminal can be available with different version of nose
- Technology with absorbing teeth

Where to use



Possibility of different types of connection to barriers



This product is:



asebal

Redirective end terminal

Physical specifications

1	Classification	Redirective
2	Length	16.270 m
3	Width	330 mm
4	Height	1400 mm
5	Weight	350 kg
6	Test level	ENV1317-4 110 Km/h

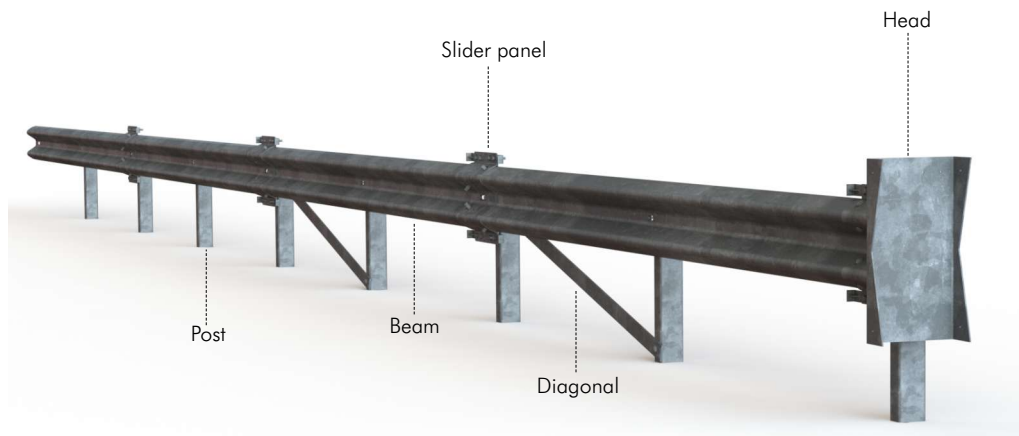

Frequently asked questions

Which kind of barrier can be connected to the ATT Terminal?

ATT Terminal can be connected to existing barriers having the same height, profile and size. Otherwise special connections to adapt to specific cases could be studied, the Technical Department of Snoline S.p.A. is able to provide assistance planning connections to the most known types of barriers.

Which maintenance requires the terminal?

ATT Terminal Requires very simple maintenance, which entails simple periodic inspections to guarantee that the system always maintains the initial characteristics of application. In case of impact we recommend applying an inspection of the system and replacement of damaged parts.

The transport of barrier terminal ATT Terminal is easy?

Given the weight of only 350 kg transportation of ATT Terminal does not involve complications. A team of 3 people can install ATT Terminal in 1 hour.