

N2	W4	A	1,2m	Severity I UNE 135900
----	----	---	------	-----------------------------

AS-SM6.B (C2) 

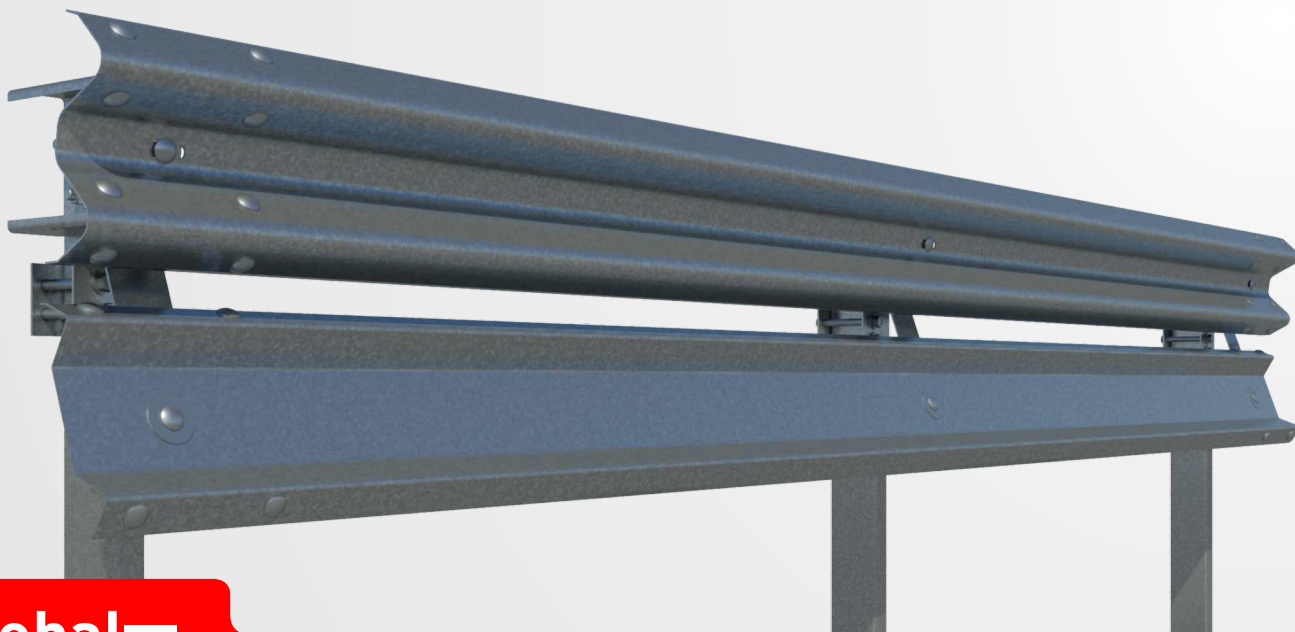



asebal 

Vehicle Restraint System

Definition

Single metal barrier for lateral side with motorcyclist protection system. System formed by a double wave barrier, spacer, a protective beam for motorcyclists and C posts 2 metres apart.

Performance parameters

Containment level	N2	Working width (W)	W4	Impact Severity	A	Dynamic Deflection (D)	1,2m
Impact Severity level	I						

Profile

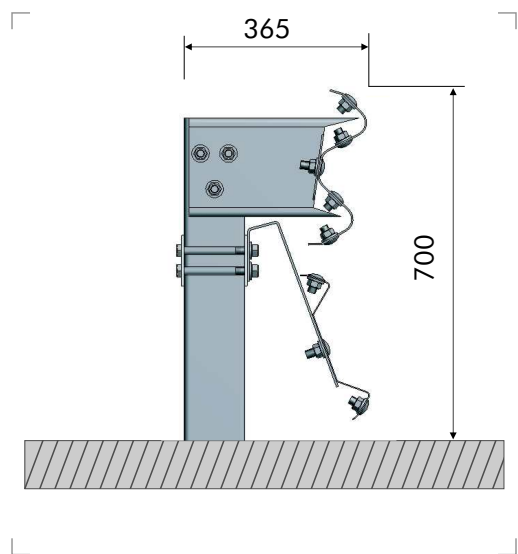

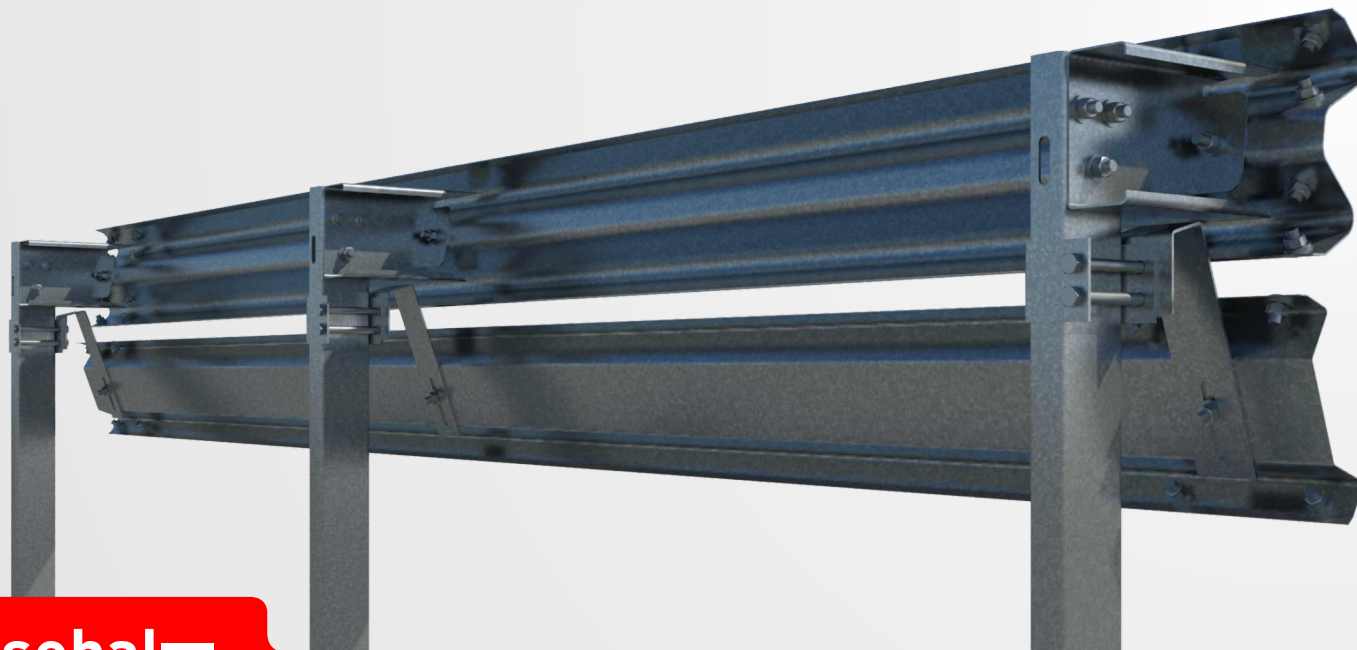

asebal

Vehicle Restraint System

Components for sections of 4 m

Item	Part	Uds
1	Standard barrier of 4 m	1
2	C post-120 of 1,500 mm	2
3	Standard spacer	2
4	Protective beam for motorists, of 4 m	1
5	Anchorage	2
6	U support	2
7	Round head bolt M16x30, with nut	12
8	Round head bolt M16x40, with nut	4
9	Hexagon head cap bolt M16x35, with nut	6
10	Hexagon head cap bolt M16x150, with nut	4
11	Washer Ø17x35x4 mm	26
12	Washer Ø70 mounting hole 30x18 e. 2mm	2
13	Reflector	0,5

Fasteners

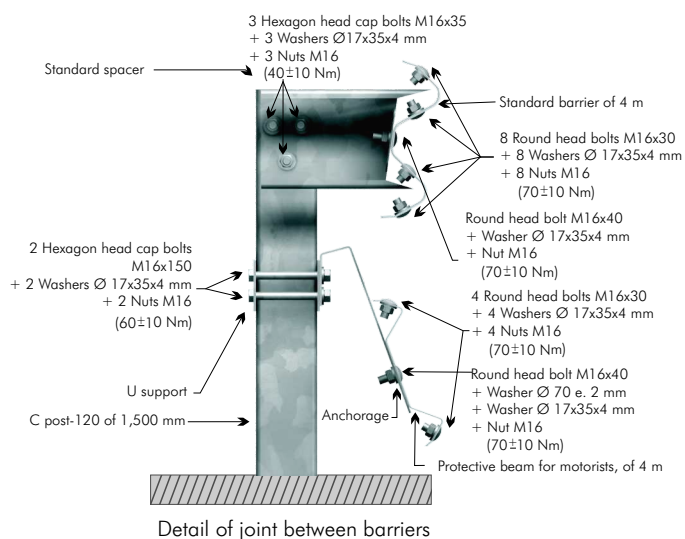

Detail of joint between barriers

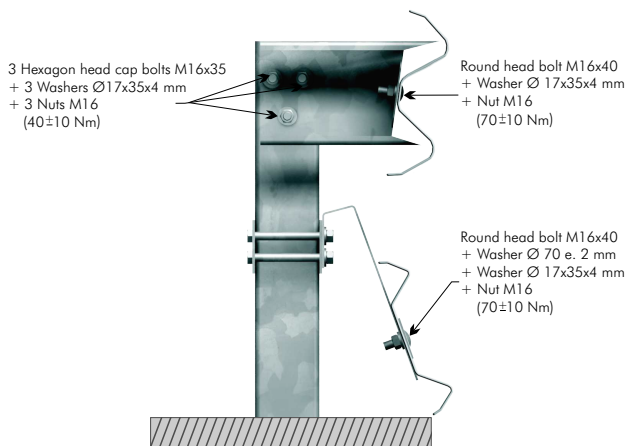

Detail of joint in intermediate post