

H1 W5 A 0,7_m

AS-BMDNA2/C

CE

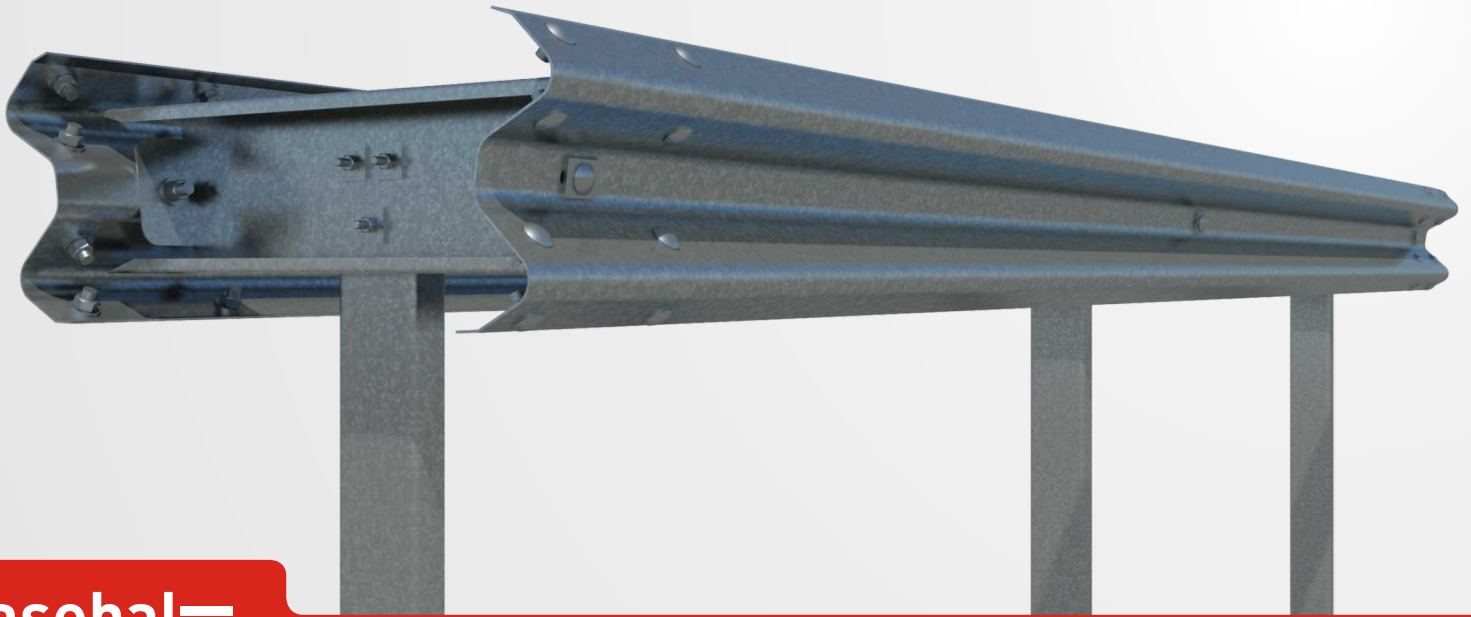

asebal

Vehicle Restraint System

Definition

Symmetrical metal barrier for median strip. System formed by two double wave barriers, symmetrical spacer and C posts 2 metres apart.

Performance parameters

Containment level	H1	Working width (W)	W5	Impact Severity	A	Dynamic Deflection (D)	0,7 _m
-------------------	----	-------------------	----	-----------------	---	------------------------	------------------

Profile

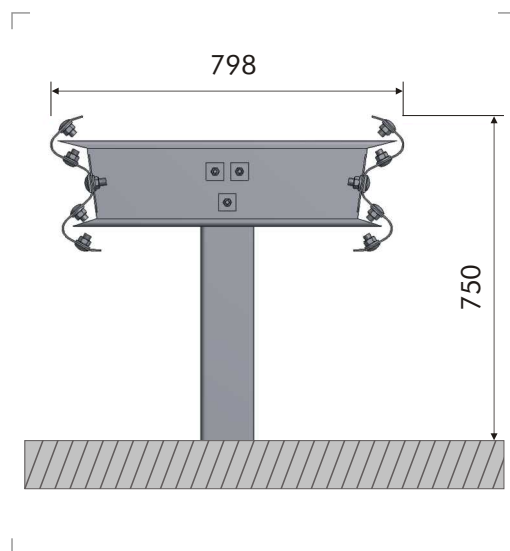

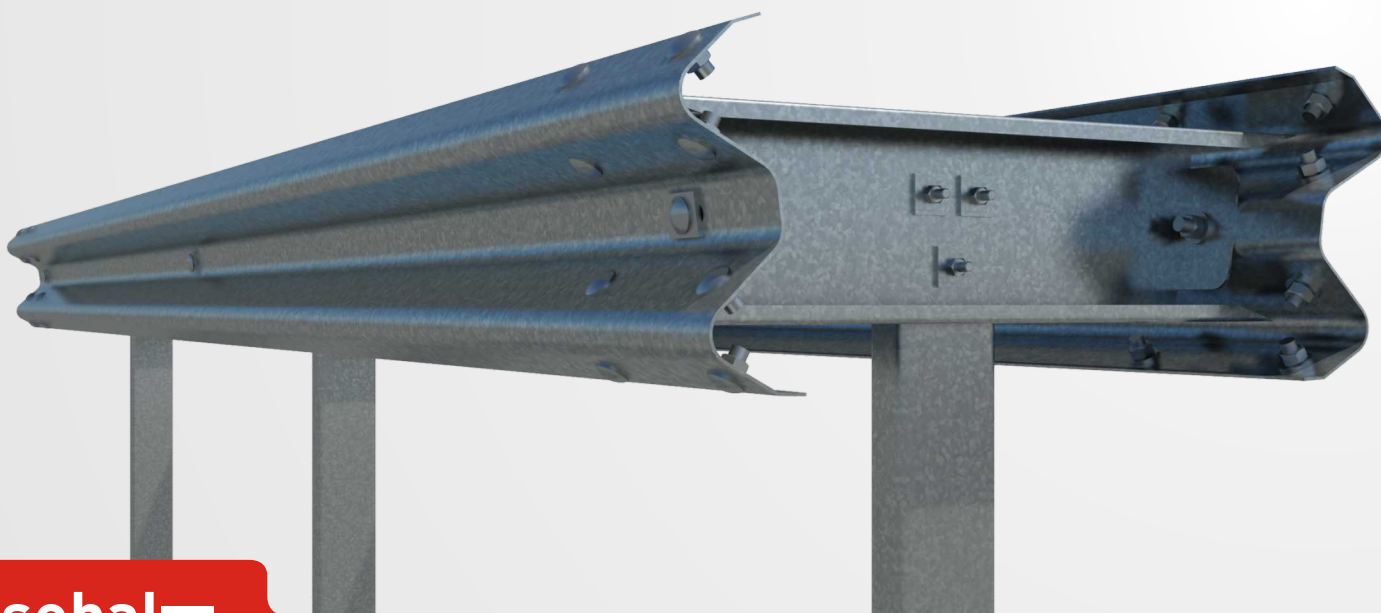

Components for sections of 4 m

Item	Part	Uds
1	Standard barrier of 4 m	2
2	C post-120 of 1,500 mm	2
3	Symmetrical spacer	2
4	Bolt M16x40, with nut	4
5	Bolt M 16x30, with nut	16
6	Bolt M10x40	6
7	M10 nut	6
8	Washer 40x40x5 mm	12
9	Rectangular washer 55x40x5 mm	4
10	Washer Ø17x35x4 mm	20
11	Reflector	1

Fasteners

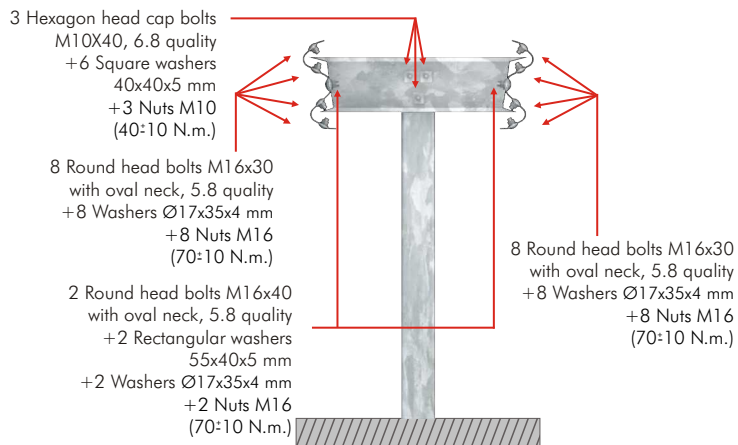

Detail of joint between barriers

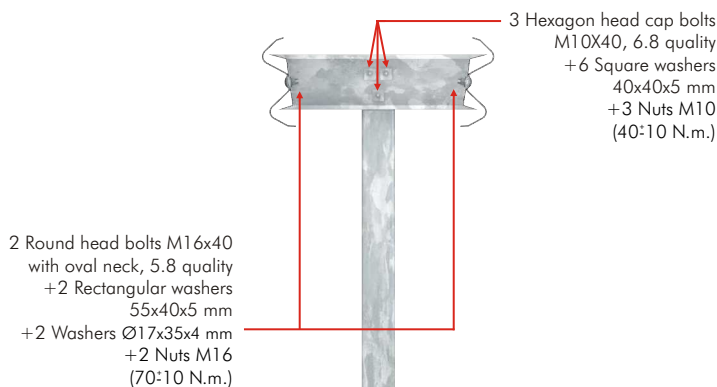

Detail of joint in intermediate post