

H1 W4 A 0,9_m VI4

AS-ME1.A(C2) 

CE

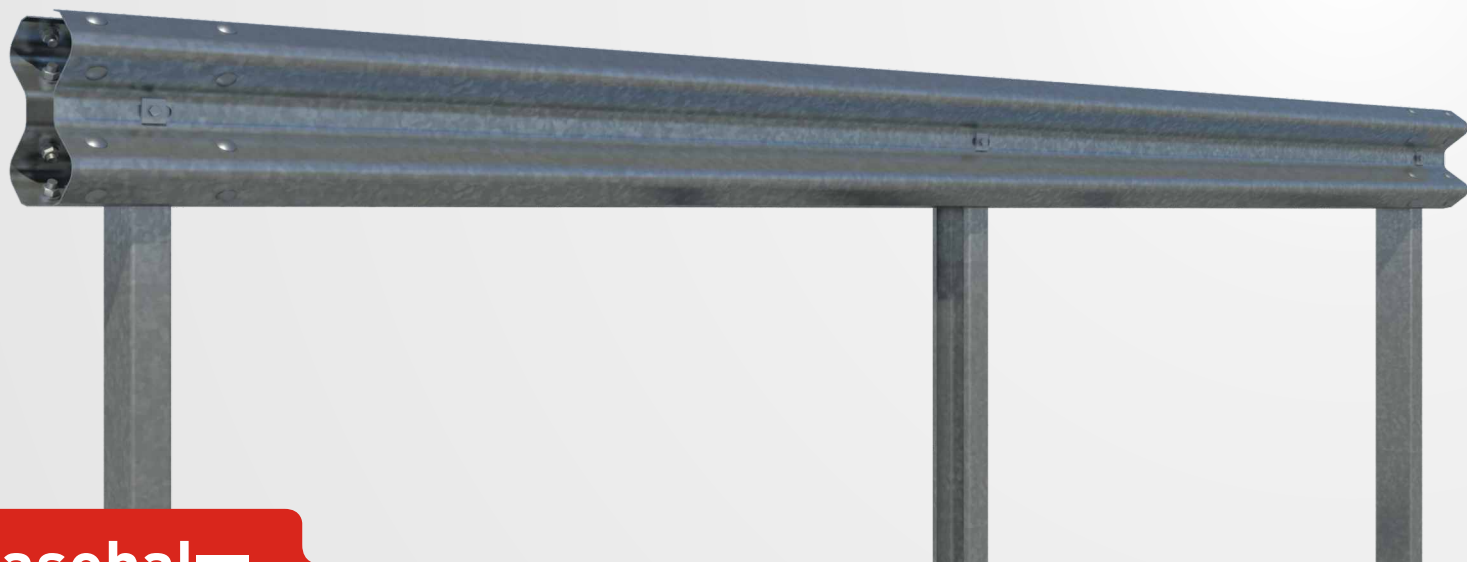

asebal 

Vehicle Restraint System

Definition

Symmetrical metal barrier for median strip. System formed by two double wave barriers, and C posts two metres apart.

Performance parameters

Containment level	H1	Working width (W)	W4	Impact Severity	A	Dynamic Deflection (D)	0,9_m
Intrusion (I)	VI4						

Profile

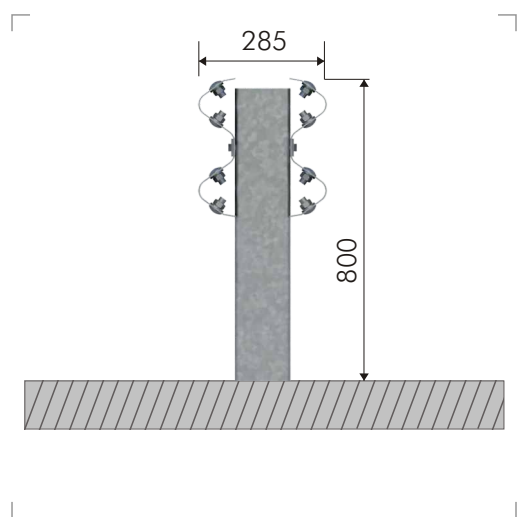

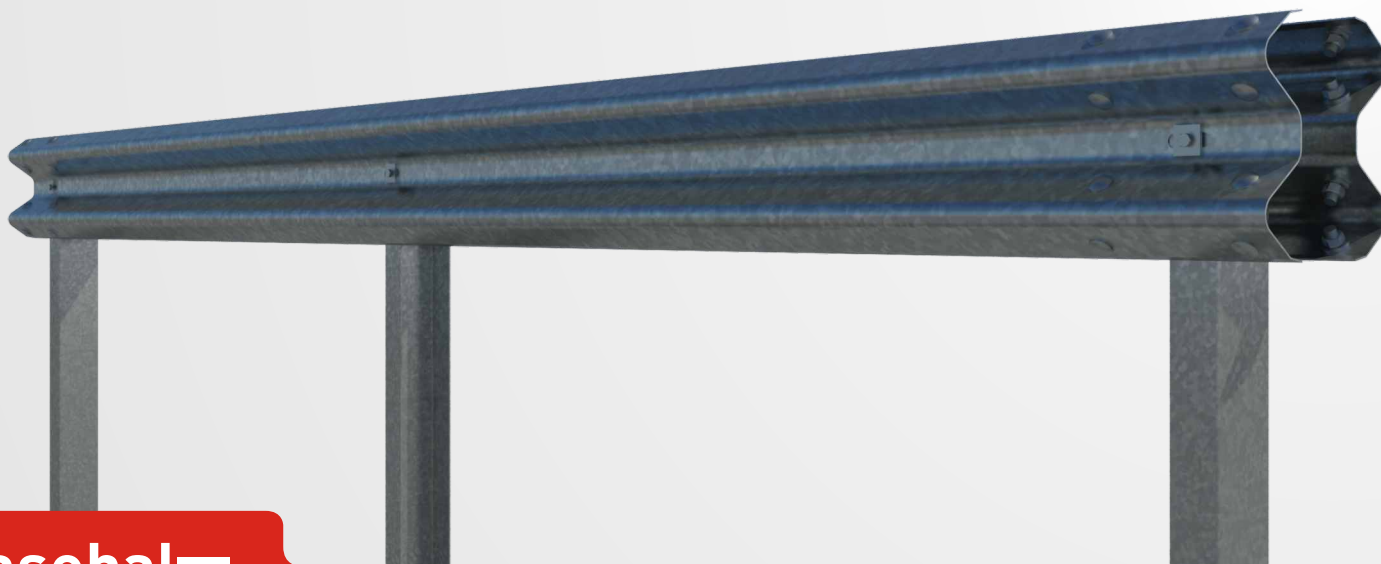

asebal

Vehicle Restraint System

Components for sections of 4 m

Item	Part	Uds
1	Straight barrier of 4 m	2
2	C post of 123x70x18x4 of 1,650 mm	2
3	Round head bolt M16x30	16
4	Bolt DIN 933 M10x40	4
5	Washer Ø17x35x4mm	16
6	Square washer 40x40x5 mm Ø11 for M10	8
7	Nut M16	16
8	Nut M10	8
9	Reflector	1

Fasteners

