

H1/L1 W4 A 1,0_m

AS-BL1.B (C2)  CE



asebal 

Vehicle Restraint System

Definition

Single metal barrier reduced for lateral side. System formed by a double wave barrier and C posts 2 metres apart.

Performance parameters

Containment level (*)	H1	Working Width (W)	W4	Impact Severity	A	Dynamic Deflection (D)	1,0_m
-----------------------	-----------	-------------------	-----------	-----------------	----------	------------------------	------------------------

(*)This system also has a L1 Containment Level as the TB-32 was tested as well.

Profile

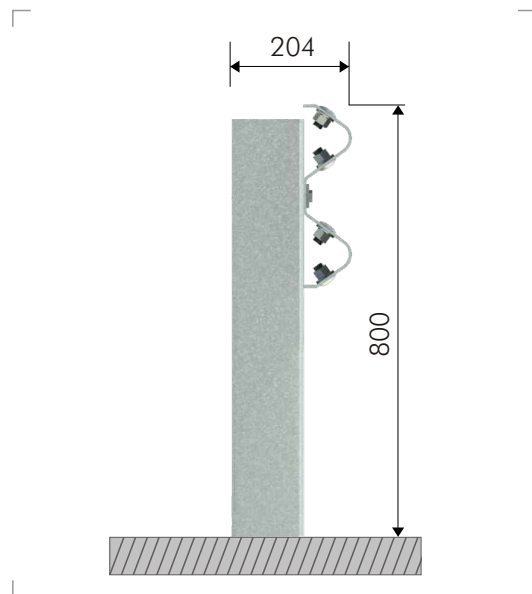

H1/L1 W4 A 1,0_m

AS-BL1.B (C2) 

CE

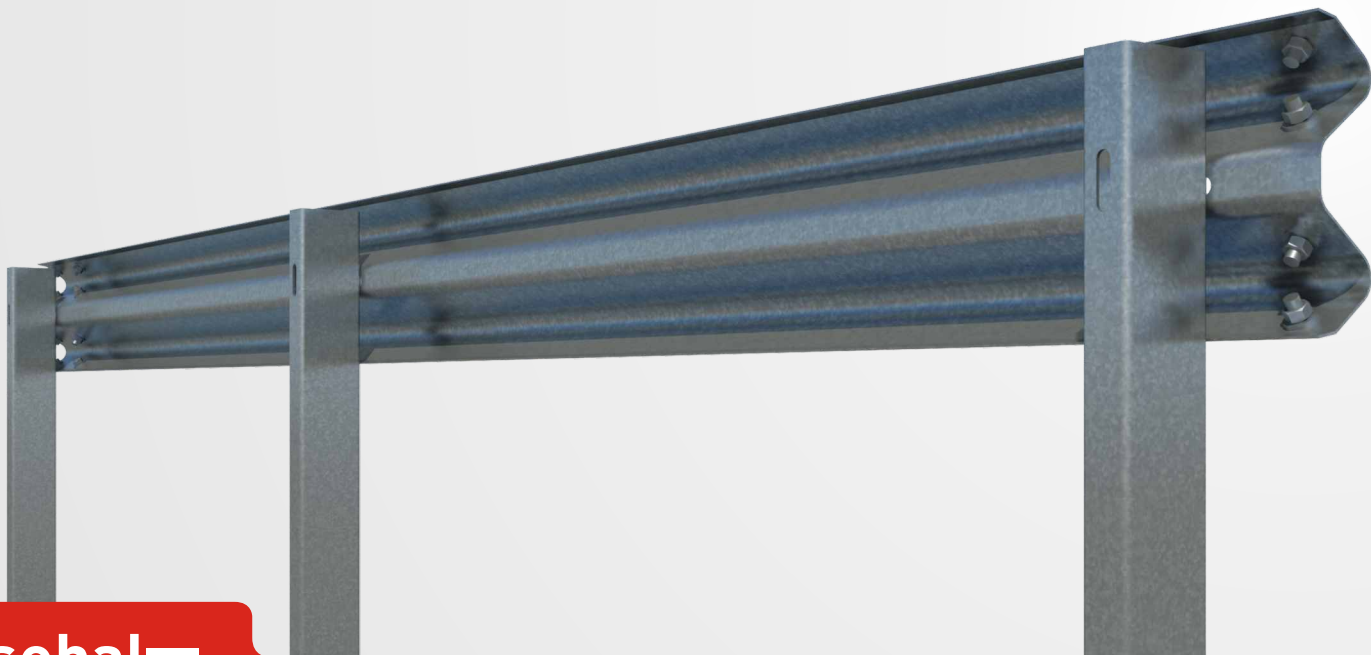

asebal 

Vehicle Restraint System

Components for sections of 4 m

Item	Part	Uds
1	Double wave barrier of 4 m	1
2	C post 123x70x18x4x1,650 mm	2
3	Reflector	0,5
4	Round head bolt M16x30, with nut	8
5	Hexagon head cap bolt M10x40	2
6	M10 nut	4
7	Washer Ø17x 35x4 mm	8
8	Square washer 40x40x5 mm	4

Fasteners

