

H3 W4 B 1,1m

APE-16h1.2  **CE**



asebal 

Vehicle Restraint System

Definition

Profile for bridges, viaducts, culverts and retaining walls on the side of the slope. System formed by three horizontal crossbeams, spacer and posts 2.5 metres apart. The system provides terminals and transitions according to the needs.

Performance parameters

Containment level	H3	Working Width (W)	W4	Impact Severity	B	Dynamic Deflection (D)	1,1m
-------------------	-----------	-------------------	-----------	-----------------	----------	------------------------	-------------

Profile

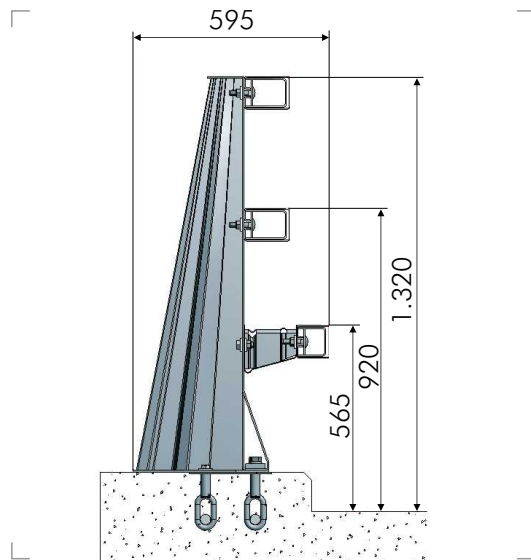

H3

W4

B

1,1m

APE-16h1.2



CE

**asebal** **Vehicle Restraint System****Components for sections of 7.5 m**

Item	Part	Uds
1	Pre-assembled post	3
2	Profile 140x100x4 mm of 7,495 mm	2
3	Profile 100x100x3 mm of 7,495 mm	1
4	Base plate 285x250x6 mm with eyebolts	3
5	Spacer	3
6	Connector of 600 mm for profile of 140x100x4 mm	2
7	Connector of 500 mm for profile 100x100x3 mm	1
8	Shear bolt M22x80	12
9	Shear bolt M16x60	6
10	Hexagon head cap bolt DIN 933 M18x40	6
11	Bolt DIN 603 M16x130	4
12	Bolt DIN 603 M20x130	8
13	Washer DIN 7989 M22	12
14	Washer 40x40x6 mm M16	6
15	Washer 40x40x6 mm M18	30
16	Washer Ø17x35x4 mm	4
17	Washer DIN 125 M20	8
18	Nut DIN 934 M18	24
19	Nut M16	4
20	Nut DIN 934 M20	8
21	Upper bracket with welded bolts	6
22	Lower bracket with welded bolts	3
23	Anchoring plate 280x60x15 mm	3

End terminal + transition components

Item	Part	Uds
1	End terminal (left/right)	1
2	Straight parapet terminal	2
3	Bolt DIN 603 M16x180	6
4	Washer 70x70x5 mm M16	6
5	Nut M16	6

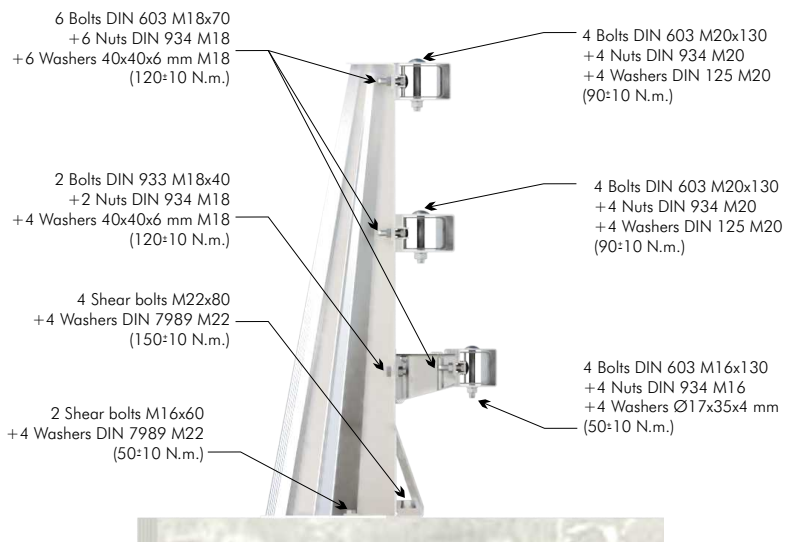
Fasteners**Notes:**

* Profiles of 4,995 mm and 2,495 mm will be used to fit the length of the sections

* The sections must be multiple of 2.5 m