

H1/L1

W4

A

1,0<sub>m</sub>

AS-BL1.B

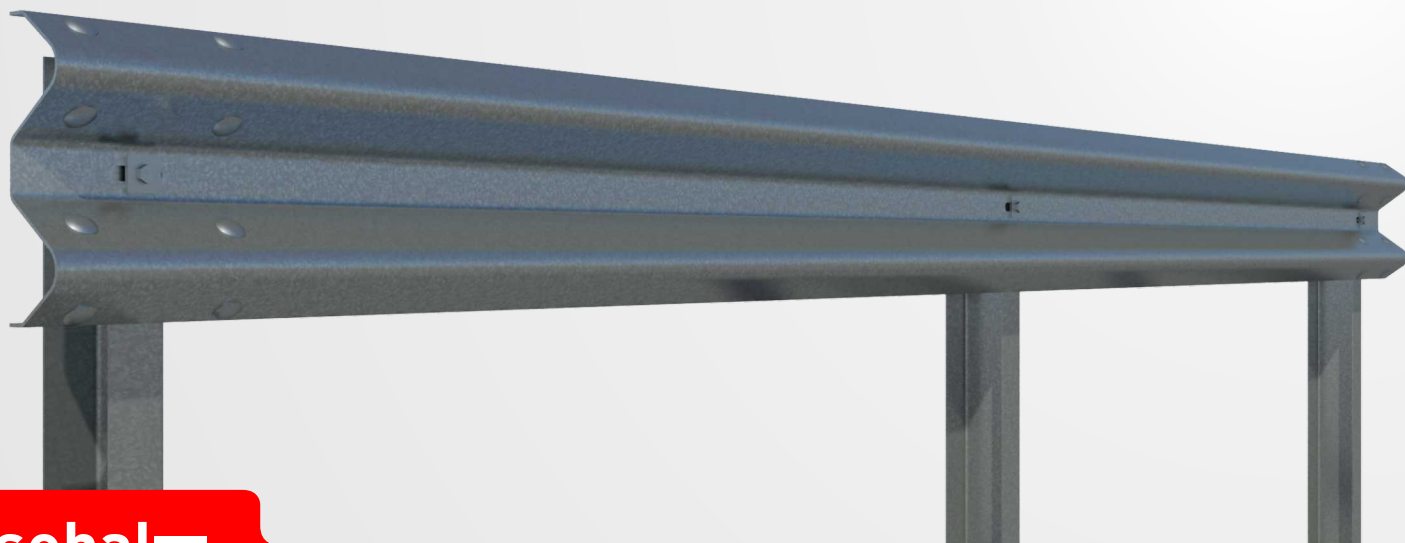

CE

**asebal**
**Vehicle Restraint System**

## Definition

Single metal barrier reduced for lateral side. System formed by a double wave barrier and U posts 2 metres apart.

## Performance parameters

Containment level (*)	<b>H1</b>	Working Width (W)	<b>W4</b>	Impact Severity	<b>A</b>	Dynamic Deflection (D)	<b>1,0<sub>m</sub></b>
-----------------------	-----------	-------------------	-----------	-----------------	----------	------------------------	------------------------

(\*)This system also has a L1 Containment Level as the TB-32 was tested as well.

## Profile

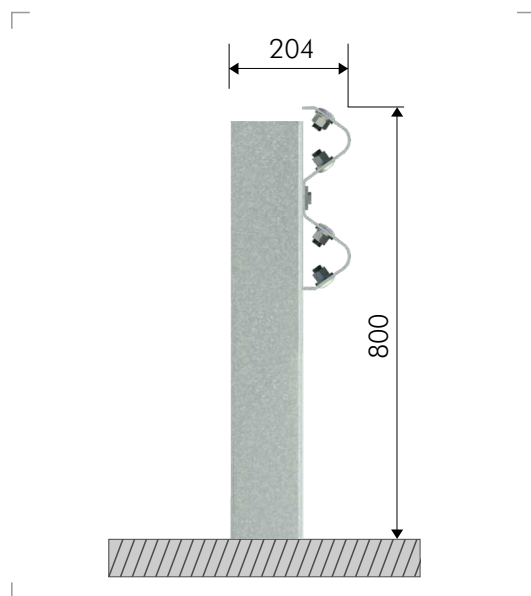

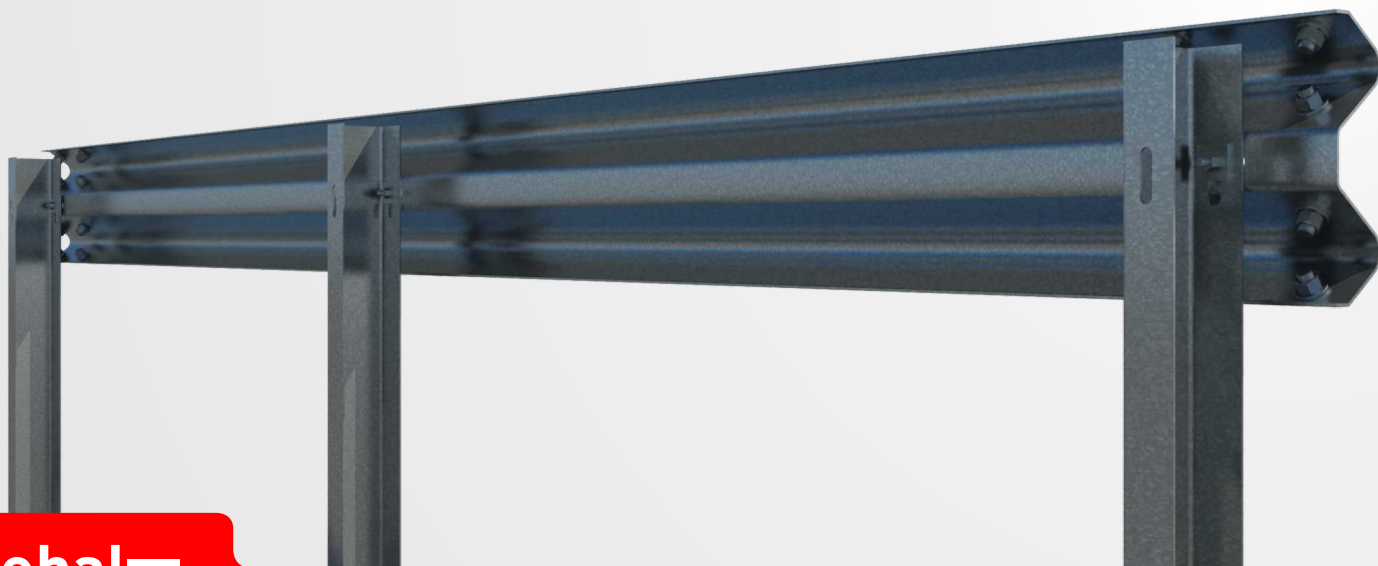

**asebal**

Vehicle Restraint System

### Components for sections of 4 m

Item	Part	Uds
1	Double wave barrier of 4 m	1
2	U post 123x70x4x1,650 mm	2
3	Reflector	0,5
4	Round head bolt M16x30, with nut	8
5	Hexagon head cap bolt M10x40	2
6	M10 nut	4
7	Washer Ø17x 35x4 mm	8
8	Square washer 40x40x5 mm	4

### Fasteners

