



N2	W5	A	1,3m	Severidad I UNE 135900
----	----	---	------	------------------------------

AS-SM6.B (I4)  

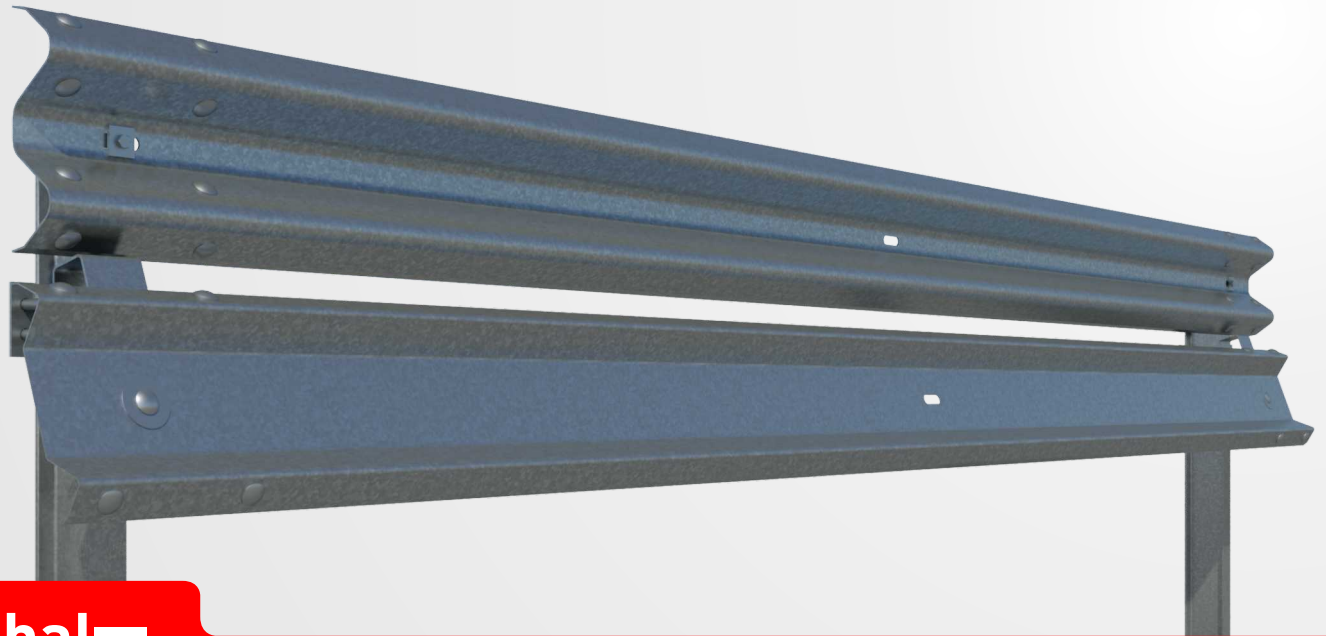

asebal 

Vehicle Restraint System

Definition

Single metal barrier reduced for lateral side with motorcyclist protection system. System formed by a double wave barrier, protective beam for motorcyclists and IPN posts 4 metres apart.

Performance parameters

Containment level	N2	Working width (W)	W5	Impact Severity	A	Dynamic Deflection (D)	1,3m
Impact Severity level	I						

Profile

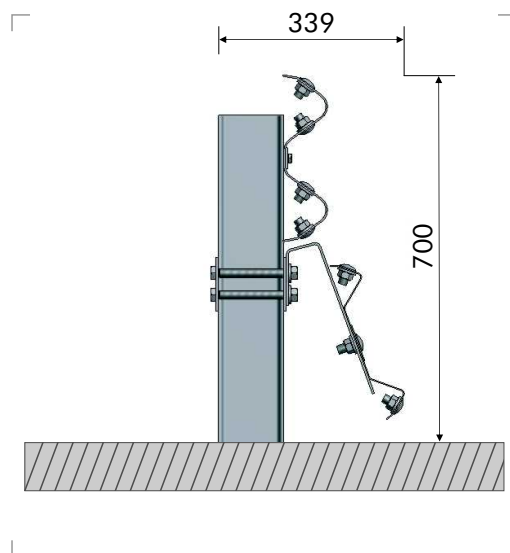

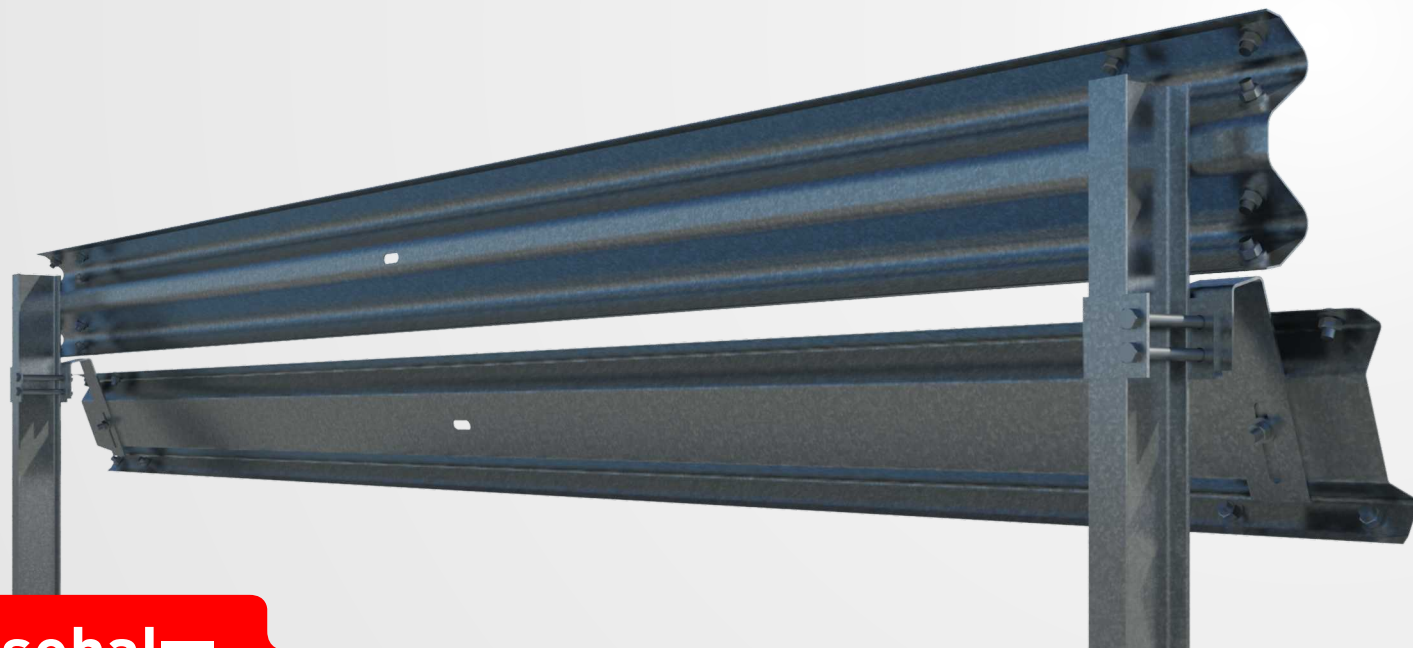

asebal

Vehicle Restraint System

Components for sections of 4 m

Item	Part	Uds
1	Standard barrier of 4 m	1
2	IPN-120 post of 1,600 mm	1
3	Protective beam for motorists, of 4 m	1
4	Anchorage	1
5	U support	1
6	Round head bolt M16x30, with nut	12
7	Round head bolt M16x40, with nut	1
8	Hexagon head cap bolt M16x150, with nut	2
9	Hexagon head cap bolt M10x40	1
10	Washer Ø17x35x4 mm	15
11	Square washer 40x40x5 mm	1
12	Rectangular washer 40x20x5 mm	1
13	Washer Ø70 mounting hole 30x18 e. 2mm	1
14	Reflector	0,5

Fasteners

