

H1	W5	A	1,0m	Severity I UNE 135900
----	----	---	------	-----------------------------

AS-SM6.B (C2-H1) 

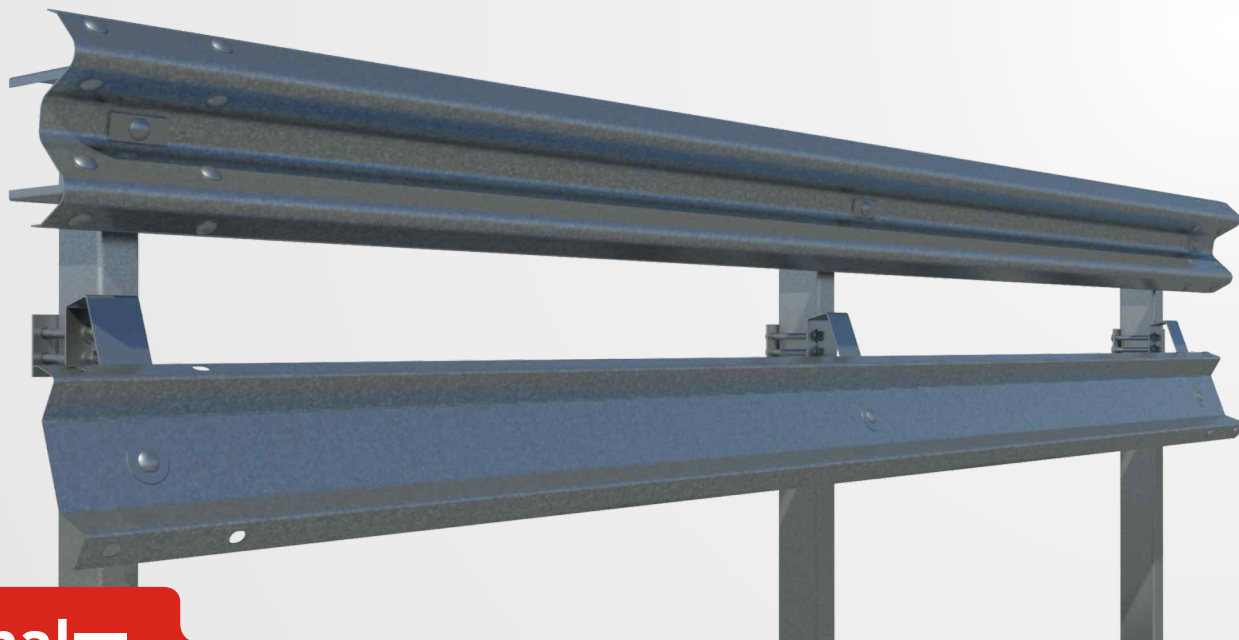



asebal 

Vehicle Restraint System

Definition

Single metal barrier for lateral side, with motorcyclist protection system. System formed by a double wave barrier, spacer, protective beam for motorcyclists and C posts 2 metres apart.

Performance Parameters

Containment Level	H1	Working Width (W)	W5	Impact Severity	A	Dynamic Deflection (D)	1,0m
Severity Level	I						

Profile

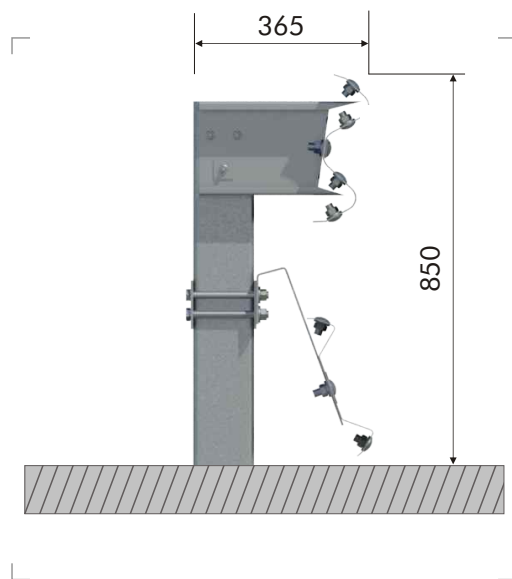

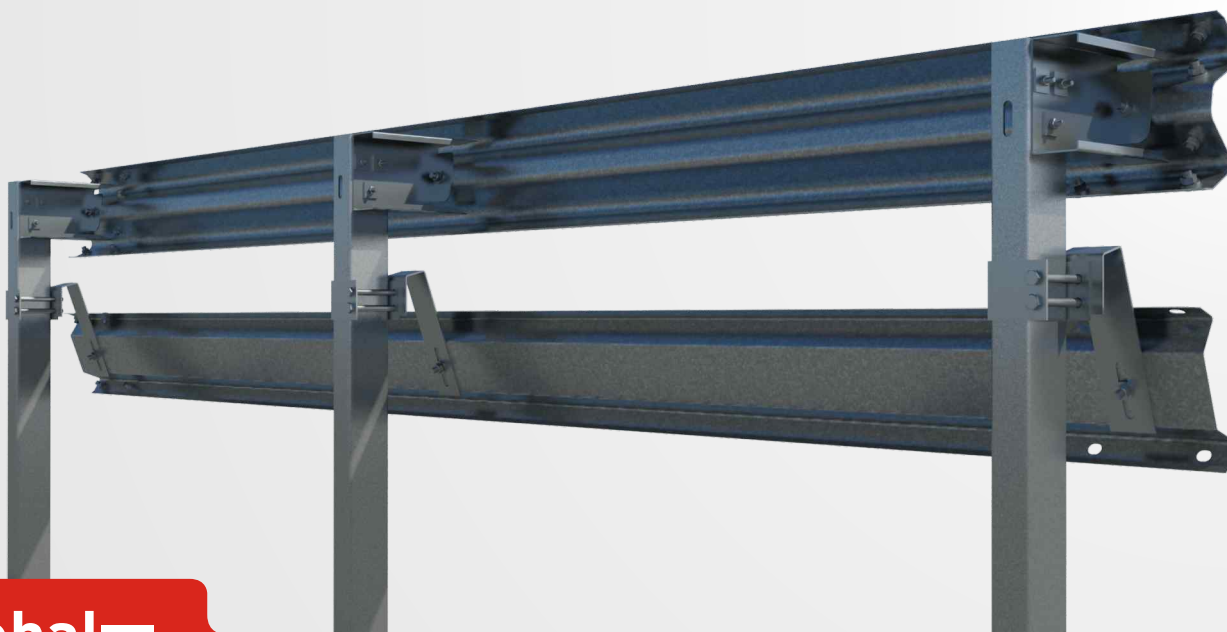

Components for sections of 4 metres

Item	Part	Us
1	Double wave barrier of 4 m	1
2	C-125 Post of 1,600 mm	2
3	Standard spacer	2
4	Protective beam for motorcyclist of 4 m	1
5	U support	2
6	Anchoring	2
7	Round Head bolt M16x40, with nut	4
8	Round Head bolt M16x30, with nut	12
9	Hexagon Head cap bolt M16x160, with nut	4
10	Hexagon Head cap bolt M10x40, with nut	6
11	Washer Ø17x35x4 mm	20
12	Washer Ø70, mounting hole 30x18 e=2 mm	2
13	Washer 40x40x5 mm	12
14	Washer 100x40x5 mm	2
15	Reflectors	0,5

Fasteners

