

N2 W5 A 1,1m

AS-BMSNA2/C

CE

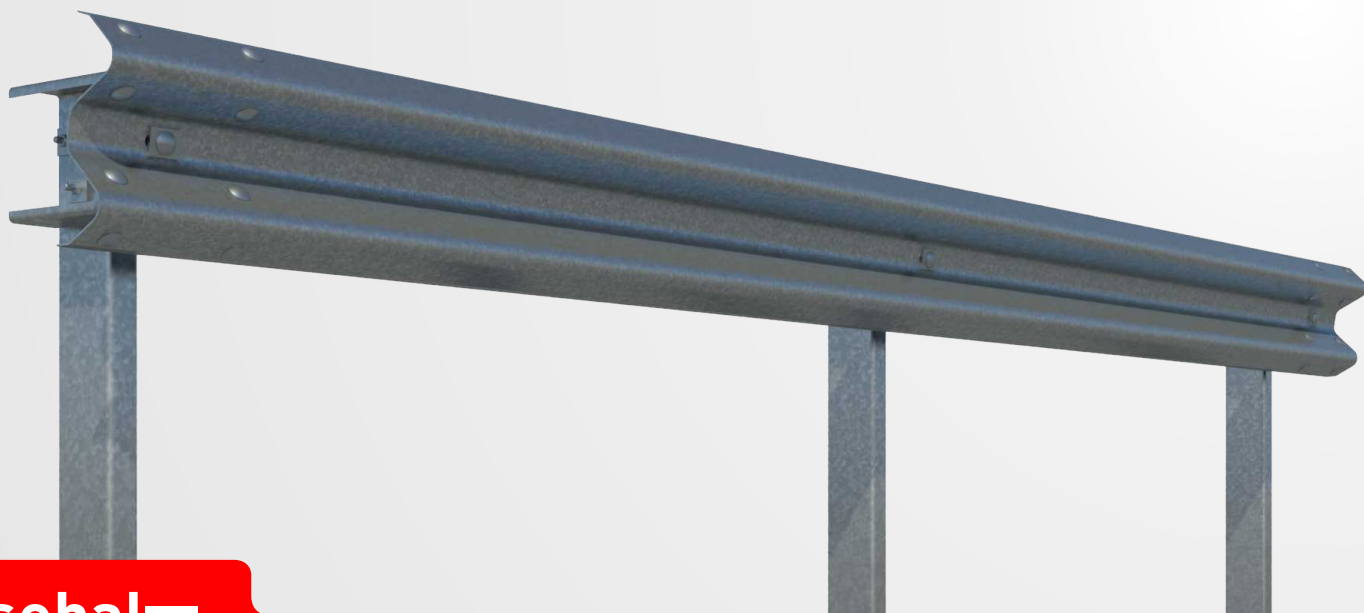

asebal

Vehicle Restraint System

### Definition

Single metal barrier reduced for lateral side. System formed by a double wave barrier, spacer and C posts 2 metres apart.

### Performance parameters

Containment level	N2	Working width (W)	W5	Impact Severity	A	Dynamic Deflection (D)	1,1m
-------------------	----	-------------------	----	-----------------	---	------------------------	------

### Profile

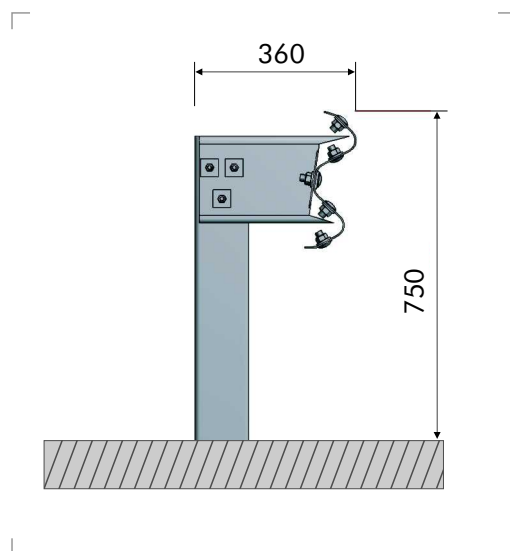

N2 W5 A 1,1<sub>m</sub>

AS-BMSNA2/C



CE

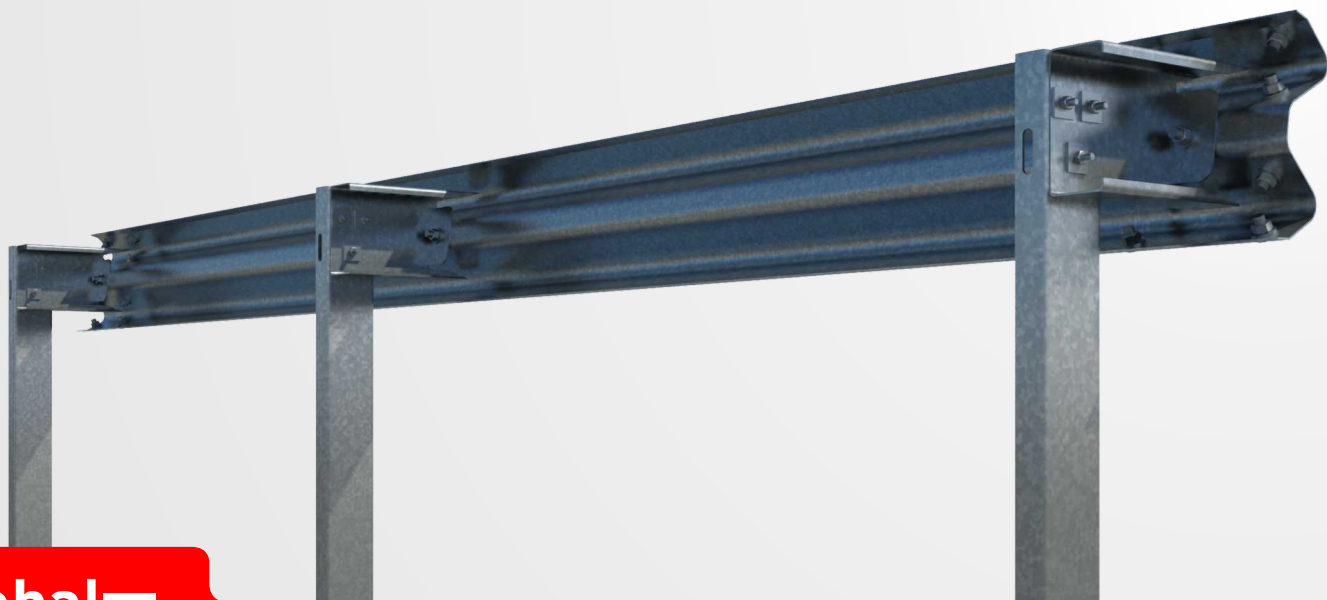

**asebal**

Vehicle Restraint System

### Components for sections of 4 m

Item	Part	Uds
1	Standard barrier of 4 m	1
2	C post-120 of 2,000 mm	2
3	Standard spacer	2
4	Bolt M16x40, with nut	2
5	Bolt M16x30, with nut	8
6	Bolt M10x40	6
7	M10 nut	6
8	Square washer 40x40x5 mm	12
9	Rectangular washer 55x40x5 mm	2
10	Washer Ø17x35x4 mm	10
11	Reflector	0,5

### Fasteners

