

H2 W5 A 1,4m

AS-BL2.A

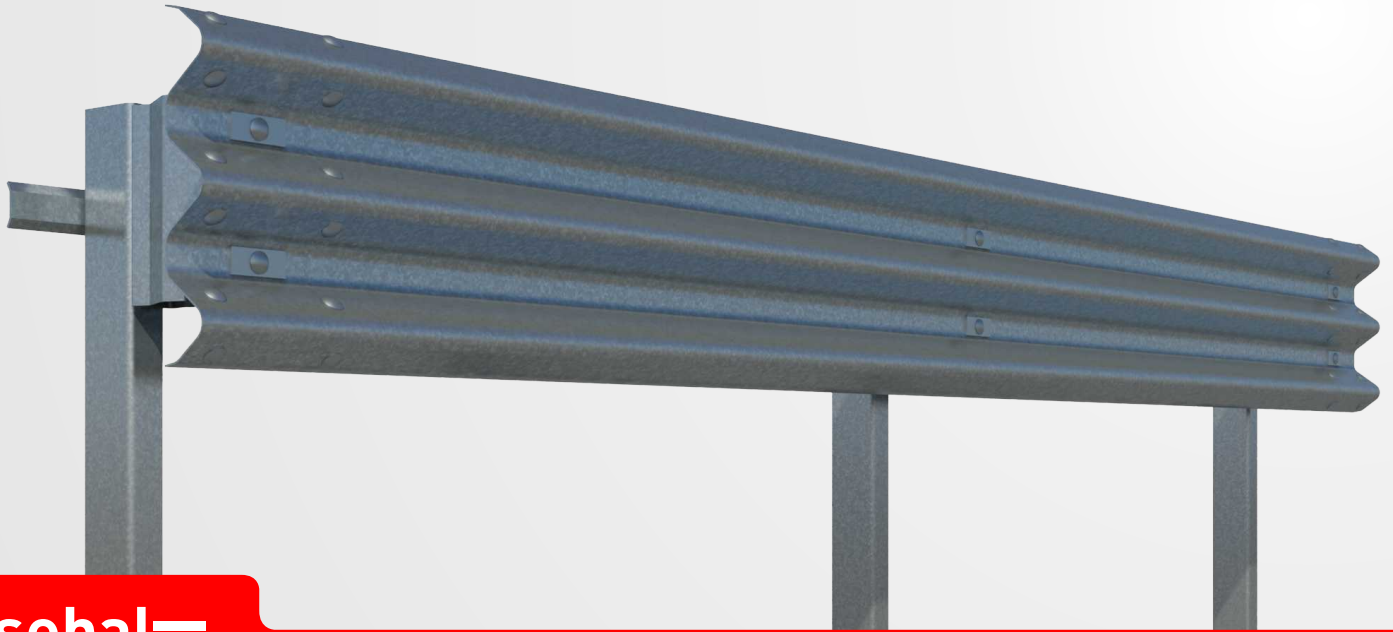

CE



asebal

Vehicle Restraint System

Definition

Single metal barrier for lateral side. System formed by a triple wave barrier, spacer, brace and U posts 2 metres apart.

Performance parameters

Containment level	H2	Working Width (W)	W5	Impact Severity	A	Dynamic Deflection (D)	1,4m
-------------------	-----------	-------------------	-----------	-----------------	----------	------------------------	-------------

Profile

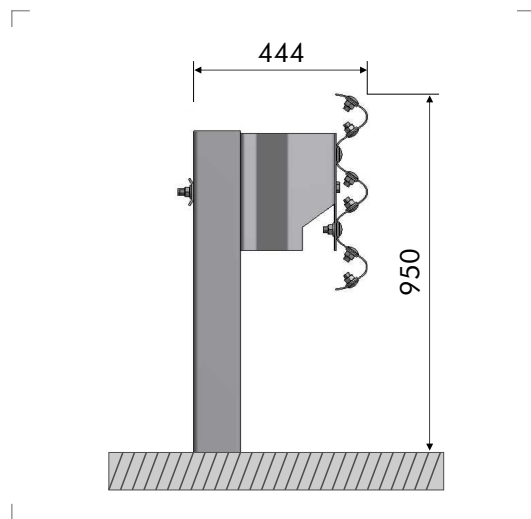

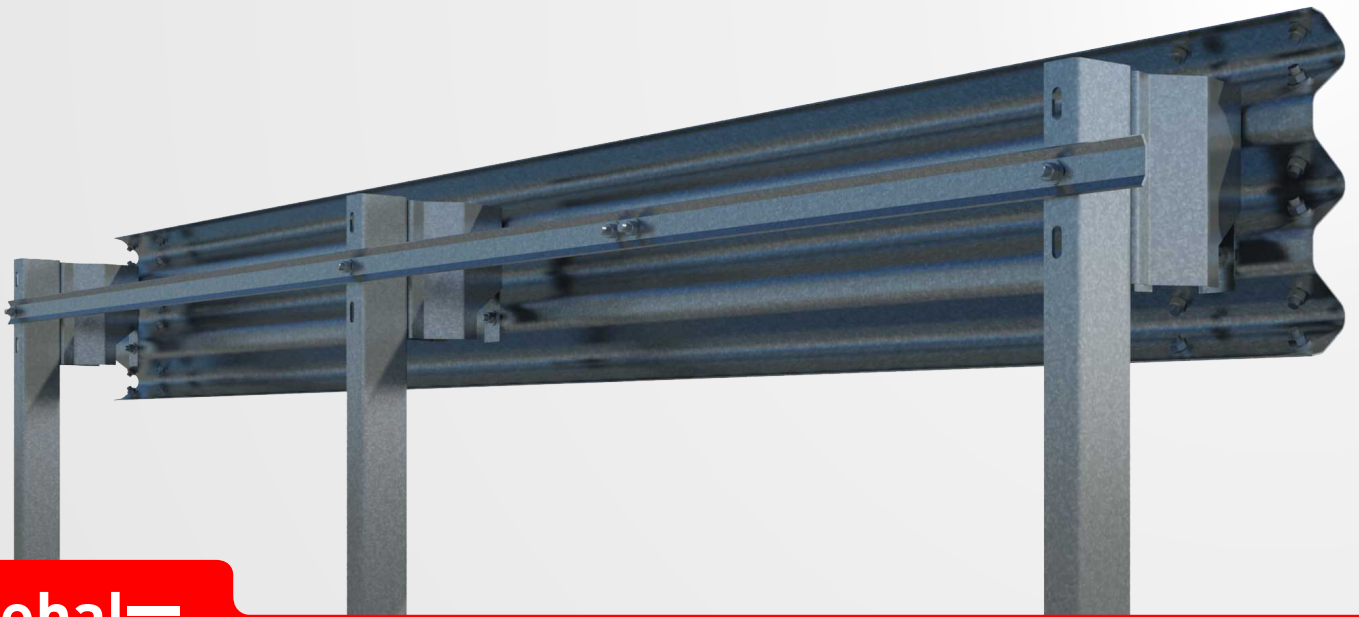

asebal

Vehicle Restraint System

Components for sections of 4 m

Item	Part	Uds
1	Triple wave barrier 4 m	1
2	U post - 120x60x6 mm of 2,000 mm	2
3	Impact attenuator for triple wave	2
4	Brace of 4,140 mm	1
5	Round head bolt M16x30, with nut	12
6	Round head bolt M16x40, with nut	8
7	Hexagon head cap bolt M16x50, with nut	6
8	Hexagon head cap bolt M16x35, with nut	2
9	Washer Ø17x 35x4 mm	28
10	Rectangular washer 100x40x5 mm, mounting hole 30x18 mm	4
11	Reflector	1

Note for the beginning and end of the section:
For each section it incorporates a brace of 3,110 mm and another brace of 1,110 mm.

Fasteners

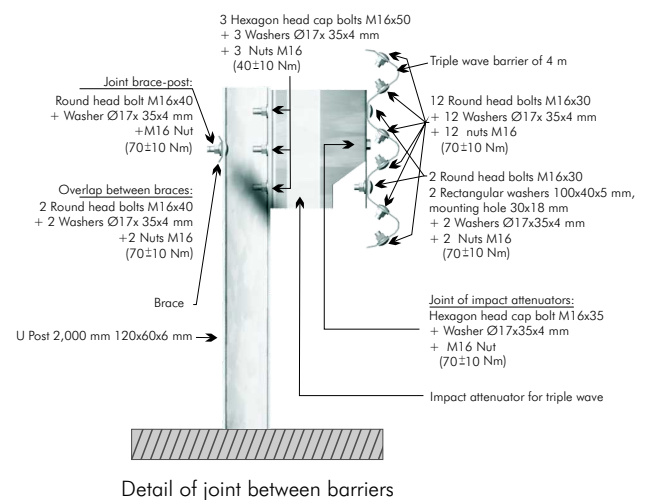

Detail of joint between barriers

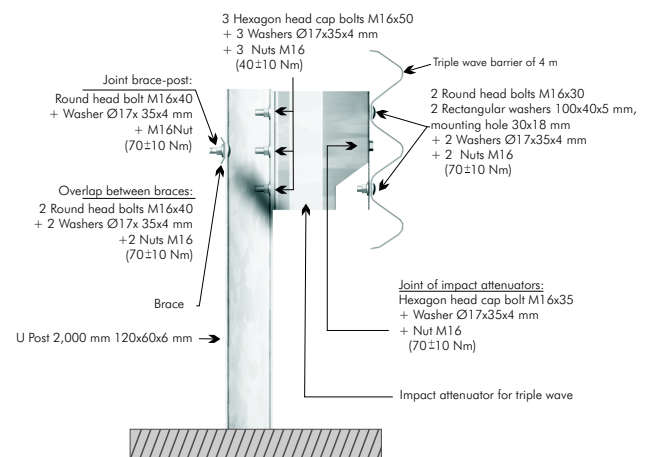

Detail of joint in intermediate post